



WORLD LEADER IN DIAPHRAGM PUMPS



Diaphragm Pumps GAMMA Series Plunger Pumps & Accessories

2011 Price List

Quality Control . . .

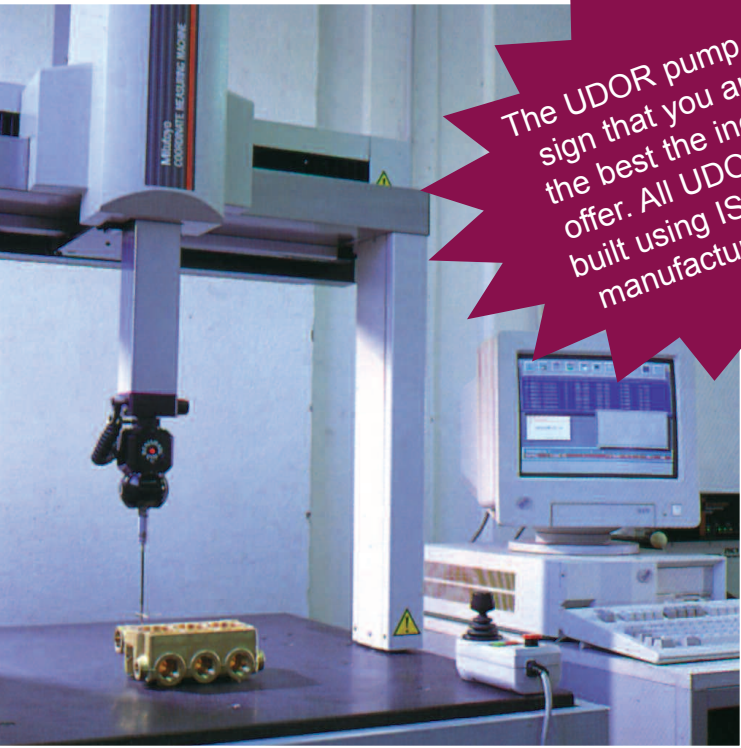

The UDOR pump logo is your sign that you are receiving the best the industry has to offer. All UDOR pumps are built using ISO 9001 quality manufacturing standards.

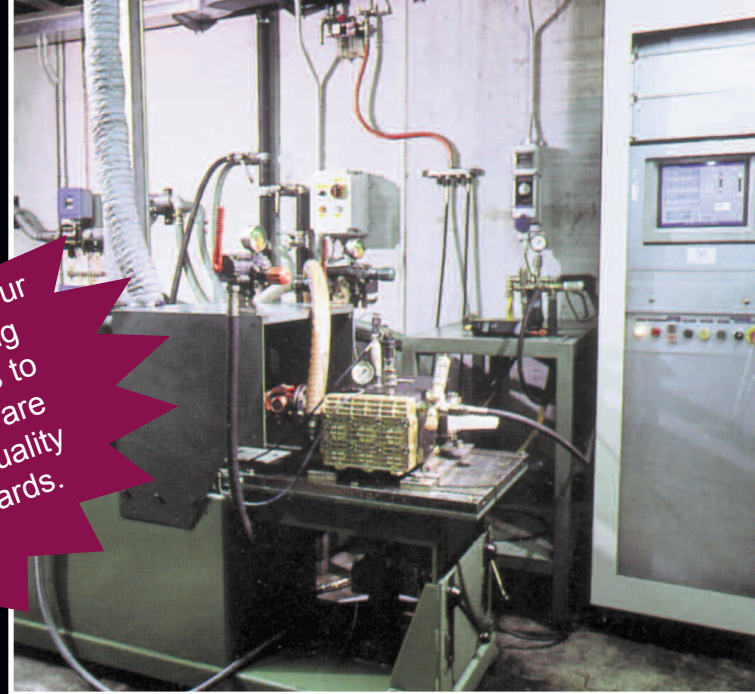

. . . Quality Testing

UDOR Diaphragm and GAMMA Series Plunger Pumps are manufactured from the highest quality materials available and are FULLY FACTORY TESTED before shipping.

UDOR Diaphragm Pumps - SIMPLY THE BEST!

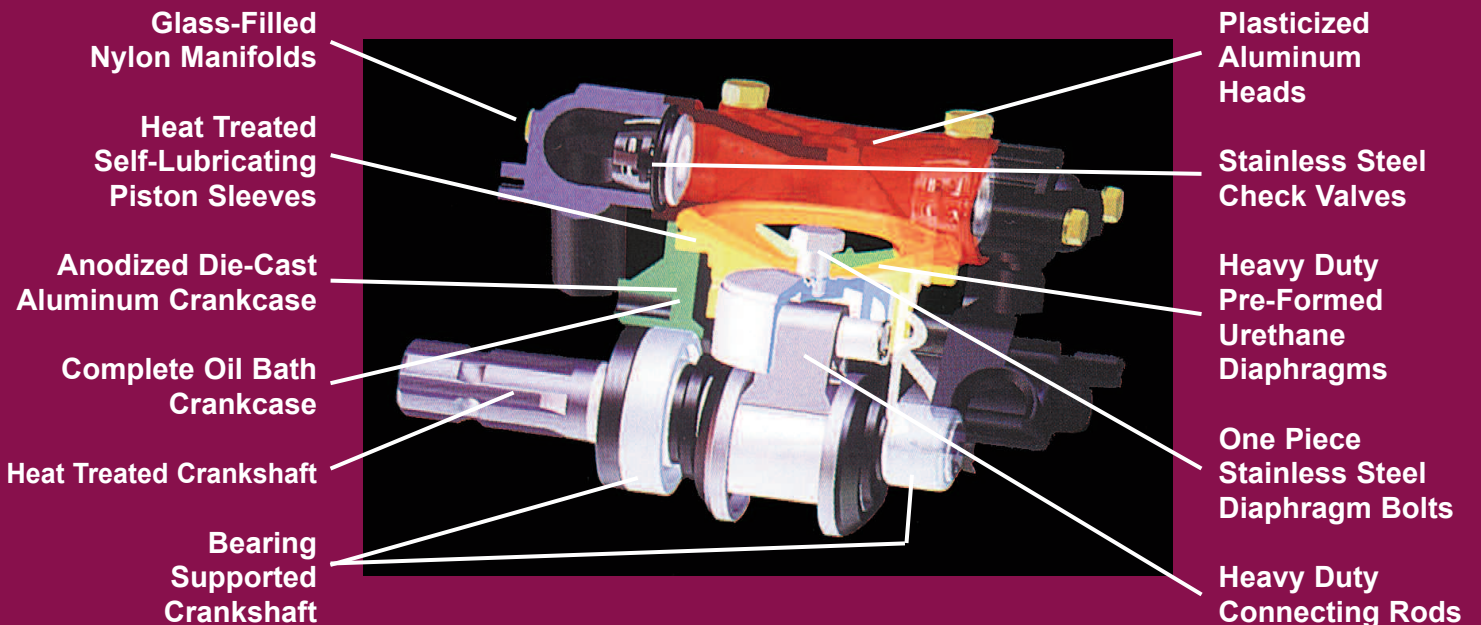

UDOR RO Series Diaphragm Pump

TABLE OF CONTENTS



DIAPHRAGM PUMPS

ZETA-Series Diaphragm Pumps	2-3
RO-Series Diaphragm Pumps	4-6, 16-17
IOTA-Series Diaphragm Pumps	7
KAPPA-Series Diaphragm Pumps	8-16
OMEGA-Series Diaphragm Pumps	17
BETA-Series Diaphragm Pumps	17-18

PLUNGER PUMPS

GAMMA-Series Plunger Pumps	18-21
Hydraulic Drive Plunger Pumps	22

PUMP OIL

UDOR Lube Premium Pump Oil	23
----------------------------	----

DRIVE COMPONENTS

Gear Reducers	23
Shaft Adapter Kits	24
Hydraulic Drive Components	25
Electric Clutch Drive Kits	26
Drive Components & Safety Shields	26-27

ACCESSORIES

Pulsation Dampeners	27
Column Sprayers	27
Trigger Valves	28
Complete Spray Guns	29-30
Spray Gun Swivels, Hose Reel Swivels & Hose Barb Swivels	31
Spray Tip Performance Charts	32
Control Units - Pump Mounted	33-35
Control Units - Remote Mounting Kits	35
Control Units - Universal	35-39
Spray Boom Controls	39
Gauges	40
Agitators	40
Filters - Inlet & High Pressure	40-41
Safety Pop-Off Valves	42
Diaphragm Pump Saver Valves	42
Inlet / Discharge fittings	42-45
Vibration Dampeners	45
Base Plates	46
Hose Reels	46
Spray Booms	46
Spray Boom Hinges	46

UDOR Diaphragm Pump Features

- Can Be Run Dry.
- Self-Priming Operation.
- Large Capacity Oil Bath Crank Cases with Drain Plugs for Ease of Maintenance.
- Compatible with Most Fluids, Including: Liquid Fertilizers, Abrasive Materials, Suspension Products, Pesticides, De-Icing Materials and Other Hard to Handle Fluids.
- Adapt Easily to PTO, Gas Engine, Hydraulic and Belt Drive Applications.
- Maximum Fluid Temperature, 140° F. Custom Pumps Available to 200° F.
- Largest Selection of Flows, Pressures and Drive Options Available.
- Over 50 Years of Diaphragm Pump Experience.
- One Piece Stainless Steel Diaphragm Bolts.
- Visual Oil Sight Gauges.
- Stainless Steel Check Valves.
- Heavy Duty Pre-Formed Urethane Diaphragms.

UDOR Diaphragm Pump Applications



- Lawn Care
- Pest Control
- Tree Spraying
- Airplane De-icing
- Firefighting
- Hydrostatic Testing
- Cleaning
- Dust Supression
- Washdown

UDOR ZETA Series Diaphragm Pumps

UDOR ZETA-40E Series diaphragm pumps have plasticized aluminum heads and glass filled nylon manifolds. Control unit is included.



UDOR ZETA-40P & ZETA-85P Series poly pumps have polypropylene and stainless steel liquid handling parts. Control unit is included.

Max. Pump Speed - 540 RPM.

MODEL	MAX. GPM	MAX. PSI	DESCRIPTION	HOSE IN	BARB OUT	PORTS BYPASS	WEIGHT (lbs.)	LIST PRICE
ZETA-40E 	10.5	300	Three diaphragm pump with universal drive face, mounting rails & control unit with adjustable pressure regulator, manual dump lever, dual ball valve outlets & pressure gauge. <i>For shaft adapter kits, see page 24</i>	1-1/4"	(2) 1/2"	3/4"	36	\$1,365.00
ZETA-40E/GR 	10.5	300	Three diaphragm pump with control unit with adjustable pressure regulator, manual dump lever, dual ball valve outlets & pressure gauge. Fitted with gear box for 4-6.5 HP gasoline engines with 3/4" shafts.	1-1/4"	(2) 1/2"	3/4"	46	\$1,830.00
ZETA-40/P 	10.5	300	Three diaphragm poly pump with universal drive face, mounting rails & control unit with adjustable pressure regulator, manual dump lever, dual ball valve outlets & pressure gauge. <i>For shaft adapter kits, see page 24</i>	1-1/4"	(2) 1/2"	3/4"	36	\$1,935.00



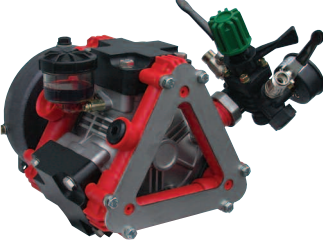
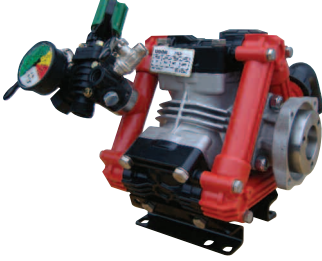

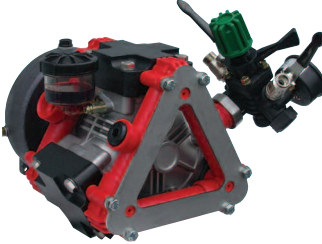
UDOR ZETA Series Diaphragm Pumps

UDOR ZETA-85 Series diaphragm pumps have plasticized aluminum heads and glass filled nylon manifolds. Control unit is included. UDOR ZETA-85P Series Poly Diaphragm Pumps have polypropylene and stainless steel liquid handling parts. Control unit is included. **Max. Pump Speed - 540 RPM.**

MODEL	MAX. GPM	MAX. PSI	DESCRIPTION	HOSE BARB PORTS			WEIGHT (lbs.)	LIST PRICE
				IN	OUT	BYPASS		
ZETA-40P/GR 	10.5	300	Three diaphragm poly pump with control unit with adjustable pressure regulator, manual dump lever, dual ball valve outlets & pressure gauge. Fitted with gear box for 4-6.5 HP gasoline engines with 3/4" shafts.	1-1/4"	(2) 1/2"	3/4"	46	\$2,440.00
ZETA-85 	22	300	Three diaphragm pump with universal drive face, mounting rails & control unit with adjustable pressure regulator, manual dump lever, dual ball valve outlets & pressure gauge. <i>For shaft adapter kits, see page 24</i>	1-1/2"	(2) 1/2"	3/4"	36	\$1,475.00
ZETA-85/GR-5 	22	300	Three diaphragm pump with control unit with adjustable pressure regulator, manual dump lever, dual ball valve outlets & pressure gauge. Fitted with gear box for 4-6.5 HP gasoline engines with 3/4" shafts.	1-1/2"	(2) 1/2"	3/4"	48	\$1,935.00
ZETA-85P 	22	300	Three diaphragm poly pump with control unit with adjustable pressure regulator, manual dump lever, dual ball valve outlets & pressure gauge. <i>For shaft adapter kits, see page 24</i>	1-1/2"	(2) 1/2"	3/4"	36	\$2,070.00
ZETA-85P/GR-5 	22	300	Three diaphragm poly pump with control unit with adjustable pressure regulator, manual dump lever, dual ball valve outlets & pressure gauge. Fitted with gear box for 4-6.5 HP gasoline engines with 3/4" shafts.	1-1/2"	(2) 1/2"	3/4"	48	\$2,565.00

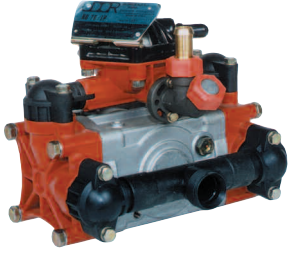



UDOR RO Series Diaphragm Pumps

UDOR RO Series pumps have plasticized aluminum heads and glass filled nylon manifolds. Control units not included. For control unit options, see pages 35-38. **Max. Pump Speed - 540 RPM.**

MODEL	MAX. GPM	MAX. PSI	DESCRIPTION	HOSE BARB PORTS			WEIGHT (lbs.)	LIST PRICE
				IN	OUT	BYPASS		
 RO-70	20	300	Two diaphragm pump with universal drive face & pulsation dampener. <i>Recommended control unit: 6047.06/LP. For shaft adapter & hydraulic kits, see page 24-25.</i>	1-1/4"	3/4"	•	33	\$1,075.00
 RO-70/GR-5	20	300	RO-70 with gear reduction for use with 5-6.5 HP gasoline engines with 3/4" shafts. <i>Recommended control unit: 6047.06/LP.</i>	1-1/4"	3/4"	•	42	\$1,595.00
 RO-110	29	300	Three diaphragm pump with universal drive face, pulsation dampener & mounting rails. <i>For shaft adapter & hydraulic kits, see page 24-25.</i>	1-1/2"	3/4"	•	45	\$1,510.00
 RO-110/C	29	300	Three diaphragm pump with pulsation dampener, mounting rails & a 1-3/8", six spline male PTO shaft. <i>PTO safety shield is included.</i>	1-1/2"	3/4"	•	45	\$1,465.00
 RO-110/GR-5	29	200	RO-110 pump with gear reduction for use with 5-6.5 HP gasoline engines with 3/4" shafts.	1-1/2"	3/4"	•	60	\$2,031.50



UDOR RO Series Diaphragm Pumps

UDOR RO Series pumps have plasticized aluminum heads and glass filled nylon manifolds. Control units not included. For control unit options, see pages 35-38. **Max. Pump Speed - 540 RPM.**

MODEL	MAX. GPM	MAX. PSI	DESCRIPTION	HOSE BARB PORTS			WEIGHT (lbs.)	LIST PRICE
				IN	OUT	BYPASS		
 <p>RO-110/GR</p>	29	300	RO-110 pump with gear reduction for use on 8-11 HP gasoline engines with 1" shafts.	1-1/2"	3/4"	•	63	\$2,135.00
 <p>RO-130/C</p>	35	300	Three diaphragm pump with pulsation dampener, mounting rails & a 1-3/8", six spline male PTO shaft. <i>PTO safety shield is included.</i>	1-1/2"	3/4"	•	45	\$1,530.00
 <p>RO-160/C</p>	42	300	Four diaphragm pump with pulsation dampener, mounting rails & a 1-3/8", six spline male PTO shaft. <i>For PTO safety shields, see page 27.</i>	1-1/2"	1"	•	56	\$2,320.00
 <p>RO-160/CC</p>	42	300	Four diaphragm pump with pulsation dampener, mounting rails & a dual 1-3/8", six spline male PTO shaft. <i>For PTO safety shields, see page 27.</i>	1-1/2"	1"	•	58	\$2,335.00
 <p>RO-160/HYD</p>	42	300	Four diaphragm pump with pulsation dampener, mounting rails & a 2-bolt A-mount flange with a female 1" keyed shaft for direct mounting of a hydraulic motor. <i>For hydraulic motor options, see Page 25. To mount hydraulic motor to pump use 12 x 30 x 1.75mm bolts</i>	1-1/2"	1"	•	58	\$2,500.00

UDOR RO Series Diaphragm Pumps

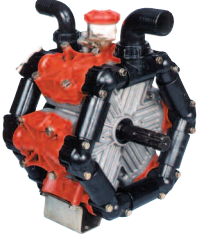
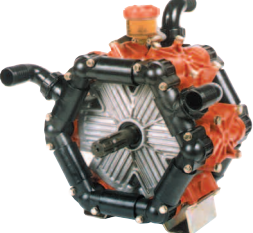
UDOR RO Series pumps have plasticized aluminum heads and glass filled nylon manifolds. Control units not included. For control unit options, see pages 35-38. **Max. Pump Speed - 540 RPM.**

MODEL	MAX. GPM	MAX. PSI	DESCRIPTION	HOSE BARB PORTS			WEIGHT (lbs.)	LIST PRICE
				IN	OUT	BYPASS		
 RO-210/CC	56	300	Six diaphragm pump with mounting rails & a dual 1-3/8", six spline male PTO shaft. <i>For PTO safety shields, see page 27.</i>	2"	1-1/2"	•	75	\$2,995.00
 RO-250/CC	65	300	Six diaphragm pump with mounting rails & a dual 1-3/8", six spline male PTO shaft. <i>For PTO safety shields, see page 27.</i>	(2) 1-1/2"	1-1/2"	•	75	\$3,080.00
 RO-250/HYD	65	300	Six diaphragm pump with mounting rails & a 2-bolt A-mount flange with a female 1" keyed shaft for direct mounting of hydraulic motor. <i>For hydraulic motor options, see page 25.</i> <i>To mount hydraulic motor to pump use 12 x 30 x 1.75mm bolts</i>	(2) 1-1/2"	1-1/2"	•	75	\$3,230.00
 RO-320/CC	84	300	Six diaphragm pump with mounting rails & a dual 1-3/8", six spline male PTO shaft. <i>For PTO safety shields, see page 27.</i>	(2) 2"	1-1/2"	•	170	\$3,790.00

FOR YOUR PROTECTION, WE RECOMMEND SAFETY SHIELDS FOR ALL PTO DRIVE & THRU SHAFT APPLICATIONS.

For Male PTO drive applications order Part # 1219.02
For Female PTO drive applications order Part # 1219.04
For Male Thru-shaft protection. order Part # 1219.15
For RO-110/C, RO-130/C, ZETA-85/C & ZETA-100/C pumps order Part # 1219.25

UDOR IOTA Series Diaphragm Pumps

UDOR IOTA Series pumps are internally manifolded with anodized aluminum construction.

Max. Pump Speed - 540 RPM.

MODEL	MAX. GPM	MAX. PSI	DESCRIPTION	HOSE BARB PORTS			WEIGHT (lbs.)	LIST PRICE
				IN	OUT	BYPASS		
 <p>IOTA-20</p>	5.0	275	Two diaphragm pump with pulsation dampener & control unit with adjustable pressure regulator, manual dump lever & pressure gauge. Also a replacement pump for any IOTA-17.	3/4"	3/8"	5/8"	14	\$715.00
 <p>IOTA-20/GR</p>	5.0	275	IOTA-20 pump with a gear reduction for 3-5 HP gasoline engines with 3/4" shafts.	3/4"	3/8"	5/8"	17	\$940.00
 <p>IOTA-20/GR-5/8</p>	5.0	275	IOTA-20 pump with a gear reduction for 2.2-3 HP gasoline engines with 5/8" shafts.	3/4"	3/8"	5/8"	17	\$940.00
 <p>IOTA-18/M</p>	4.5	200	IOTA-18 pump with 115V TEFC motor w/ 10 amp draw. Complete with on/off switch, overload protection with manual reset, handle & base plate	3/4"	3/8"	5/8"	33	\$1,435.00
0908.31			115-Volt Motor Only				25	\$961.90
 <p>IOTA-18/E</p>	4.5	200	Replacement pump for IOTA-17/M & IOTA-18/M.	3/4"	3/8"	5/8"	14	\$715.00

UDOR KAPPA Series Diaphragm Pumps

UDOR KAPPA Series pumps are internally manifolded with anodized aluminum construction.



*KAPPA-7,15,18 have glass filled, nylon heads. **Max. Pump Speed - 540 RPM.***

MODEL	MAX. GPM	MAX. PSI	DESCRIPTION	HOSE BARB PORTS		MAX. AMP DRAW	WEIGHT (lbs.)	LIST PRICE
				IN	OUT			
 KAPPA-7/12 Volt 0908.42	2.0	200	Two diaphragm pump with pulsation dampener. Equipped with 12-volt DC motor. Gravity feed only. <i>Recommended control valve, Part #UD1/4-300.</i>	3/4"	3/8"	25	22	\$1,065.00
			12-Volt DC Motor Only				12	\$536.00
 KAPPA-15/12 Volt 0908.42	3.5	90	Two diaphragm pump with pulsation dampener. Equipped with 12-volt DC motor. <i>Recommended control valve, Part #UD1/4-150.</i>	3/4"	1/2"	25	22	\$1,065.00
			12-Volt DC Motor Only				12	\$536.00
 KAPPA-18/12 Volt 0908.42	4.2	70	Two diaphragm pump with pulsation dampener. Equipped with 12-volt DC motor. <i>Recommended control valve, Part #UD1/4-150.</i>	3/4"	1/2"	28	22	\$1,115.00
			12-Volt DC Motor Only				12	\$536.00
 KAPPA-15/12 Volt-HP 0908.50	3.5	200	Two diaphragm pump with pulsation dampener. Equipped with heavy duty 12-volt DC motor. <i>Recommended control valve, Part #UD1/4-300.</i>	3/4"	1/2"	35	35	\$1,345.00
			HD 12-Volt DC Motor Only				24	\$808.70
 KAPPA-18/12 Volt-HP 0908.50	4.2	150	Two diaphragm pump with pulsation dampener. Equipped with heavy duty 12-volt DC motor. <i>Recommended control valve, Part #UD1/4-150.</i>	3/4"	1/2"	35	35	\$1,410.00
			HD 12-Volt DC Motor Only				24	\$808.70

UDOR KAPPA Series Diaphragm Pumps

UDOR KAPPA Series pumps are internally manifolded with anodized aluminum construction.

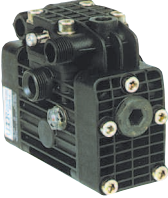
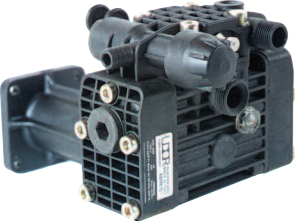
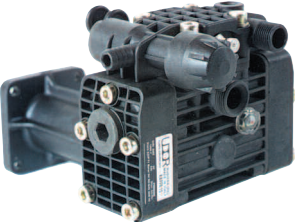

KAPPA-7,15,18 have glass filled, nylon heads. **Max. Pump Speed - 540 RPM.**

MODEL	MAX. GPM	MAX. PSI	DESCRIPTION	HOSE BARB PORTS		MAX. AMP DRAW	WEIGHT (lbs.)	LIST PRICE
				IN	OUT			
KAPPA-7/115 Volt 	2.0	200	Two diaphragm pump with pulsation dampener. Equipped with 115 volt TEFC motor. Includes stub cord and on/off switch. <i>Recommended control valve, Part #UD1/4-300.</i>	3/4"	3/8"	10	25	\$1,270.00
KAPPA-7,15,18/DC 	2.0 3.5 4.2	• • •	Replacement pump for KAPPA-7,15,18/12-Volt assembly.	3/4" 3/4" 3/4"	3/8" 1/2" 1/2"	• • •	8 8 8	\$560.00 \$560.00 \$615.00
KAPPA-15/GR 	3.5	275	Two diaphragm pump with pulsation dampener & adjustable pressure regulator. Equipped with a gear reduction for 3-5 HP gasoline engines with 3/4" shafts.	3/4"	3/8"	5/8"	10	\$775.00
KAPPA-15/GR-5/8 	3.5	275	Two diaphragm pump with pulsation dampener & adjustable pressure regulator. Equipped with a gear reduction for 2.2-3 HP gasoline engines with 5/8" shafts.	3/4"	3/8"	5/8"	10	\$775.00
KAPPA-25 	7	350	Two diaphragm pump with pulsation dampener & control unit with adjustable pressure regulator, manual dump valve, dual ball valve outlets & pressure gauge. Equipped with a 25 mm keyed shaft & mounting rails.	1"	(2) 1/2"	3/4"	18	\$920.00

UDOR KAPPA Series Diaphragm Pumps

UDOR KAPPA Series pumps are internally manifolded with anodized aluminum construction.

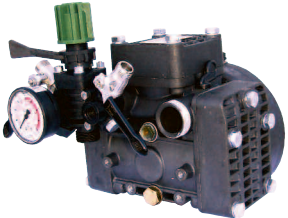
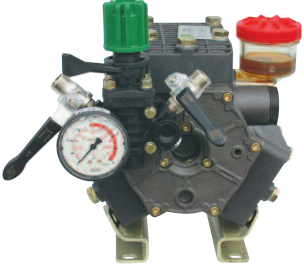
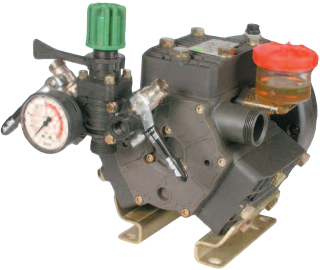

*Three diaphragm pumps include mounting rails. **Max. Pump Speed - 540 RPM.***

MODEL	MAX. GPM	MAX. PSI	DESCRIPTION	HOSE BARB PORTS			WEIGHT (lbs.)	LIST PRICE
				IN	OUT	BYPASS		
 <p>KAPPA-25/GR</p>	7.0	350	Two diaphragm pump with pulsation dampener & control unit with adjustable pressure regulator, manual dump lever, dual ball valve outlets & pressure gauge. Equipped with a gearbox for 3-5.5 HP gasoline engines with 3/4" shafts.	1"	(2) 1/2"	3/4"	28	\$1,060.00
 <p>KAPPA-30</p>	9.5	350	Two diaphragm pump with universal drive face, pulsation dampener & control unit with adjustable pressure regulator, manual dump lever, dual ball valve outlets & pressure gauge.	1"	(2) 1/2"	3/4"	28	\$1,040.00
 <p>KAPPA-30/GR HR</p>	9.5	560	KAPPA-30 pump with control unit and gear reduction for 4-6.5 HP gasoline engines with 3/4" shafts. Direct replacement for D30 GRGI.	1"	(2) 1/2"	3/4"	39	\$1,555.00
 <p>KAPPA-33</p>	8.5	560	Three diaphragm pump with control unit with adjustable pressure regulator, manual dump lever, dual ball valve outlets & pressure gauge. Equipped with a 25mm keyed shaft & mounting rails.	1"	(2) 1/2"	3/4"	29	\$1,040.00
 <p>KAPPA-33/GR</p>	8.5	560	Three diaphragm pump with control unit with adjustable pressure regulator, manual dump lever, dual ball valve outlets & pressure gauge. Fitted with gearbox for 4-6.5 HP gasoline engines with 3/4" shafts.	1"	(2) 1/2"	3/4"	39	\$1,540.00

UDOR KAPPA Series Diaphragm Pumps

UDOR KAPPA Series pumps are internally manifolded with anodized aluminum construction.

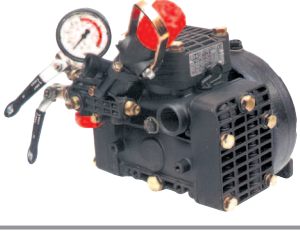
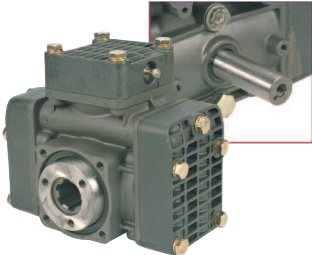

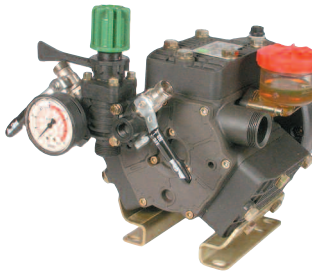

*Three diaphragm pumps include mounting rails. **Max. Pump Speed - 540 RPM.***

MODEL	MAX. GPM	MAX. PSI	DESCRIPTION	HOSE BARB PORTS			WEIGHT (lbs.)	LIST PRICE
				IN	OUT	BYPASS		
<p>KAPPA-40</p> 	10.5	560	Two diaphragm pump with universal drive face, pulsation dampener & control unit with adjustable pressure regulator, manual dump lever, dual ball valve outlets & pressure gauge.	1"	(2) 1/2"	3/4"	29	\$1,070.00
<p>KAPPA-40/GR</p> 	10.5	560	KAPPA-40 pump with gear reduction for 4-6.5 HP gasoline engines with 3/4" shafts.	1"	(2) 1/2"	3/4"	39	\$1,555.00
<p>KAPPA-40/TS</p> 	10.5	560	<p>KAPPA-40 pump with universal drive face on back & 25 mm keyed shaft on front.</p> <p><i>To convert 25 mm shaft to a male 6-spline PTO shaft, order part #0005.22.</i></p> <p><i>For PTO safety shields, see page 27.</i></p>	1"	(2) 1/2"	3/4"	30	\$1,130.00
<p>KAPPA-43</p> 	10.5	560	Three diaphragm pump with control unit with adjustable pressure regulator, manual dump lever, dual ball valve outlets & pressure gauge. Equipped with a 25mm keyed shaft & mounting rails.	1"	(2) 1/2"	3/4"	29	\$1,070.00
<p>KAPPA-43/GR</p> 	10.5	560	<p>Three diaphragm pump with control unit with adjustable pressure regulator, manual dump lever, dual ball valve outlets & pressure gauge.</p> <p>Fitted with gearbox for 4-6.5 HP gasoline engines with 3/4" shafts.</p>	1"	(2) 1/2"	3/4"	39	\$1,555.00

UDOR KAPPA Series Diaphragm Pumps

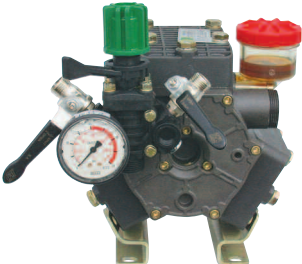
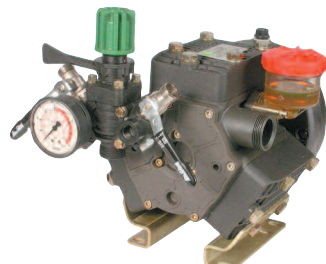
UDOR KAPPA Series pumps are internally manifolded with anodized aluminum construction.





*Three diaphragm pumps include mounting rails. **Max. Pump Speed - 540 RPM.***

MODEL	MAX. GPM	MAX. PSI	DESCRIPTION	HOSE BARB PORTS			WEIGHT (lbs.)	LIST PRICE
				IN	OUT	BYPASS		
 <p>KAPPA-53</p>	12.5	560	Three diaphragm pump with control unit with adjustable pressure regulator, manual dump lever, dual ball valve outlets & pressure gauge. Equipped with a 25mm keyed shaft & mounting rails.	1-1/4"	(2) 1/2"	3/4"	29	\$1,105.00
 <p>KAPPA-53/GR</p>	12.5	560	Three diaphragm pump with control unit with adjustable pressure regulator, manual dump lever, dual ball valve outlets & pressure gauge. Fitted with gearbox for 4-6.5 HP gasoline engines with 3/4" shafts.	1-1/4"	(2) 1/2"	3/4"	39	\$1,765.00
 <p>KAPPA-55</p>	15	560	Three diaphragm pump with universal drive face, pulsation dampener & control unit with adjustable pressure regulator, manual dump lever, dual ball valve outlets & pressure gauge.	1-1/4"	(2) 1/2"	3/4"	37	\$1,410.00
 <p>KAPPA-55/GR-5</p>	15	350	KAPPA-55 pump with gear reduction for 5-6.5 HP gasoline engines with 3/4" shafts.	1-1/4"	(2) 1/2"	3/4"	47	\$1,905.00
 <p>KAPPA-55/GR-8</p>	15	560	KAPPA-55 pump with gear reduction for 8-11 HP gasoline engines with 1" shafts.	1-1/4"	(2) 1/2"	3/4"	49	\$2,020.00

UDOR KAPPA Series Diaphragm Pumps

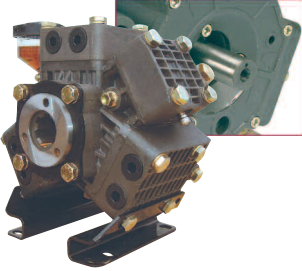
UDOR KAPPA Series pumps are internally manifolded with anodized aluminum construction.





Three and four diaphragm pumps include mounting rails. **Max. Pump Speed - 540 RPM.**

MODEL	MAX. GPM	MAX. PSI	DESCRIPTION	HOSE IN	BARB OUT	PORTS BYPASS	WEIGHT (lbs.)	LIST PRICE
 <p>KAPPA-55/TS</p>	15	560	<p>KAPPA-55 pump with universal drive face on back & 25 mm keyed shaft on front.</p> <p><i>To convert 25 mm shaft to a male 6-spline PTO shaft, order part #0005.22.</i></p> <p><i>For PTO safety shields, see page 27.</i></p>	1-1/4"	(2) 1/2"	3/4"	38	\$1,520.00
 <p>KAPPA-75</p>	20	560	<p>Three diaphragm pump with universal drive face, pulsation dampener & control unit with adjustable pressure regulator, manual dump lever, dual ball valve outlets & pressure gauge.</p>	1-1/4"	(2) 1/2"	3/4"	46	\$1,815.00
 <p>KAPPA-75/GR</p>	20	560	<p>KAPPA-75 pump with gear reduction for 9-13 HP gasoline engines with 1" shafts.</p>	1-1/4"	(2) 1/2"	3/4"	58	\$2,430.00
 <p>KAPPA-75/TS</p>	20	560	<p>KAPPA-75 pump with universal drive face on back & male 6-spline PTO shaft on the front.</p> <p><i>For PTO safety shields, see page 27.</i></p>	1-1/4"	(2) 1/2"	3/4"	48	\$1,955.00
 <p>KAPPA-100</p>	26	560	<p>Four diaphragm pump with universal drive face has pulsation dampener & control unit with adjustable pressure regulator, manual dump lever, dual ball valve outlets & pressure gauge.</p>	1-1/2"	(2) 1/2"	3/4"	52	\$2,075.00

UDOR KAPPA Series Diaphragm Pumps

UDOR KAPPA Series pumps are internally manifolded with anodized aluminum construction.



Four diaphragm pumps include mounting rails. **Max. Pump Speed - 540 RPM.**

MODEL	MAX. GPM	MAX. PSI	DESCRIPTION	HOSE BARB PORTS			WEIGHT (lbs.)	LIST PRICE
				IN	OUT	BYPASS		
 <p>KAPPA-100/C</p>	26	560	<p>Four diaphragm pump with pulsation dampener & control unit with adjustable pressure regulator, manual dump lever, dual ball valve outlets & pressure gauge. Has 1-3/8", 6-spline male PTO shaft.</p> <p><i>For PTO safety shields, see page 27.</i></p>	1-1/2"	(2) 1/2"	3/4"	52	\$2,020.00
 <p>KAPPA-100/C IND</p>	26	560	<p>Four diaphragm pump with pulsation dampener & control unit with adjustable pressure regulator, manual dump lever, steel bypass barb, one 3/4" FNPT outlet & pressure gauge has a 1-3/8" 6-spline male shaft.</p>	1-1/2"	3/4" Female NPT	3/4"	55	\$2,085.00
 <p>KAPPA-100/GR</p>	26	560	<p>KAPPA-100 with gear reduction for use on 16-18 HP gasoline engines with 1" shafts.</p>	1-1/2"	(2) 1/2"	3/4"	72	\$2,915.00
 <p>KAPPA-120/TS</p>	35	700	<p>Four diaphragm pump with pulsation dampener & control unit with adjustable pressure regulator, manual dump lever & pressure gauge.</p> <p>Has universal drive face on the back & a 1-3/8", 6-spline male PTO shaft on the front.</p> <p><i>For PTO safety shields, see page 27.</i></p>	1-1/2"	(1) 3/4" Male NPT	1"	105	\$3,415.00
 <p>KAPPA-120/CC</p>	35	700	<p>Four diaphragm pump with pulsation dampener & control unit with adjustable pressure regulator, manual dump lever & pressure gauge. Has dual 1-3/8", 6-spline male PTO shaft.</p> <p><i>For PTO safety shields, see page 27.</i></p>	1-1/2"	(2) 1/2" (1) 3/4" Female NPT	1"	105	\$3,275.00

UDOR KAPPA Series Diaphragm Pumps

UDOR KAPPA Series pumps are internally manifolded with anodized aluminum construction.

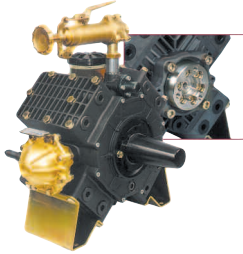
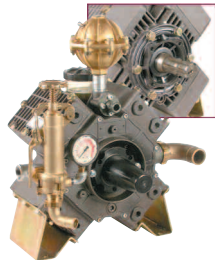
Four diaphragm pumps include mounting rails. **Max. Pump Speed - 540 RPM.**

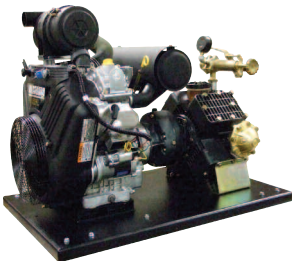
MODEL	MAX. GPM	MAX. PSI	DESCRIPTION	HOSE IN	BARB OUT	PORTS BYPASS	WEIGHT (lbs.)	LIST PRICE
 <p>KAPPA-120/GR</p>	35	700	KAPPA-120 with gear reduction for use on 18-23 HP gasoline engines with 1" shafts.	1-1/2"	(1) 3/4" Male NPT	1"	130	\$4,210.00
 <p>KAPPA-150/TS</p>	42	700	Four diaphragm pump with pulsation dampener & control unit with adjustable pressure regulator, manual dump lever & pressure gauge. Has universal drive face on the back & a 1-3/8", 6-spline male PTO shaft on the front. <i>For PTO safety shields, see page 27.</i>	1-1/2"	(1) 3/4" Male NPT	1"	105	\$3,900.00
 <p>KAPPA-150/CC</p>	42	700	Four diaphragm pump with pulsation dampener & control unit with adjustable pressure regulator, manual dump lever & pressure gauge. Has dual 1-3/8", 6-spline male PTO shaft. <i>For PTO safety shields, see page 27.</i>	1-1/2"	(1) 3/4" Male NPT (1) 3/4" Female NPT	1"	105	\$3,765.00
 <p>KAPPA-150/GR</p>	42	700	KAPPA-150 with gear reduction for use on 24-35 HP gasoline engines with 1-1/8" shafts.	1-1/2"	(1) 3/4" Male NPT	1"	135	\$4,580.00
 <p>KAPPA-150/GR-ASSY</p>	42	700	KAPPA-150/GR heavy duty diaphragm pump with gear reduction, pressure regulator, pulse dampener and pressure gauge. 31 HP Briggs big block engine with throttle control keyswitch, electric start and choke. Heavy gauge steel base plate with black powder coated finish and eight rubber support bumpers. 36" L x 24" W x 30" H	1-1/2"	(1) 3/4" Male NPT	1"	300	\$11,770.00

UDOR KAPPA and RO Series Super Duty Belt Drive Diaphragm Pumps

UDOR USA's Super Duty Belt Drive units have fan cooled TEFC industrial motors with ball bearing supported armatures, balanced pulleys, grip notch belts, 'Rough Coat' powder coated base plates, belt guards and four heavy duty rubber support bumpers for extended life and smooth quiet operation.

MODEL	MAX. GPM	MAX. PSI	DESCRIPTION	HOSE IN	BARB OUT	PORTS BYPASS	MAX AMP	WEIGHT (lbs.)	LIST PRICE
 KAPPA-30/12V	6	150	Super Duty Belt Drive KAPPA-30 with industrial duty 3/4 HP, 12-volt fan cooled TEFC motor. <i>Contact UDOR USA for control unit options.</i>	1-1/4"	3/4" Male NPT	•	40	100	\$3,505.00
06-1080.48			12 Volt DC Motor Only					30	\$1,039.40
 KAPPA-40/12V	8	100	Super Duty Belt Drive KAPPA-40 with industrial duty 3/4 HP, 12-volt fan cooled TEFC motor. <i>Contact UDOR USA for control unit options.</i>	1-1/4"	3/4" Male NPT	•	40	100	\$3,505.00
06-1080.48			12 Volt DC Motor Only					30	\$1,039.40
 KAPPA-30/115V	6	300	Super Duty Belt Drive KAPPA-30 with industrial duty 1.5 HP, 115-volt fan cooled TEFC motor. Includes 6010.24/LP control unit, On/Off switch & stub cord.	1-1/4"	1/2"	3/4"	15	100	\$3,505.00
06-1160.68			115 Volt Motor Only					30	\$662.60
 KAPPA-40/115V	8	200	Super Duty Belt Drive KAPPA-40 with industrial duty 1.5 HP, 115-volt fan cooled TEFC motor. Includes 6010.24/LP control unit, On/Off switch & stub cord.	1-1/4"	1/2"	3/4"	15	100	\$3,505.00
06-1160.68			115 Volt Motor Only					30	\$662.60
 RO-70/12V	12	70	Super Duty Belt Drive RO-70 with industrial duty 3/4 HP, 12-volt fan cooled TEFC motor.	1-1/4"	3/4" Male NPT	•	40	100	\$3,605.00
06-1080.48			12 Volt DC Motor Only					30	\$1,039.40

MODEL	MAX. GPM	MAX. PSI	DESCRIPTION	HOSE BARB PORTS			MAX. AMP	WEIGHT (lbs.)	LIST PRICE
				IN	OUT	BYPASS			
RO-70/115V 	12	150	Super Duty Belt Drive RO-70 with industrial duty 1.5 HP, 115-volt fan cooled TEFC motor. Includes 6047.06/LP control unit, On/Off switch & stub cord.	1-1/4"	(2) 1/2"	3/4"	15	100	\$3,605.00
06-1160.68			115 Volt Motor Only					30	\$662.60

UDOR OMEGA Series Diaphragm Pumps

UDOR OMEGA Series pumps have plasticized aluminum heads, plasticized aluminum manifolds, steel connecting rods, mounting rails and a dual 1-3/8" six spline male shaft.

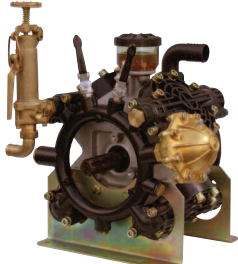
MODEL	MAX. GPM	MAX. PSI	DESCRIPTION	HOSE BARB PORTS			WEIGHT (lbs.)	LIST PRICE
				IN	OUT	BYPASS		
OMEGA-140/CC 	39	700	Three diaphragm pump with pulsation dampener & control unit with adjustable pressure regulator, manual dump lever, dual ball valve outlets & pressure gauge. Has dual 1-3/8", 6-spline male PTO shaft. <i>For PTO safety shields, see page 27.</i>	1-1/2"	(2) 1/2" (2) 3/4" Female NPT	1"	100	\$3,250.00
OMEGA-170/CC 	46	700	Four diaphragm pump with pulsation dampener & control unit with adjustable pressure regulator, manual dump lever, dual ball valve outlets & pressure gauge. Has dual 1-3/8", 6-spline male PTO shaft. <i>For PTO safety shields, see page 27.</i>	1-1/2"	(2) 1/2" (2) 3/4" Female NPT	1"	120	\$3,770.00

UDOR BETA Series Diaphragm Pumps

UDOR BETA Series pumps have brass heads, stainless steel and brass manifolds, steel connecting rods, mounting rails and a dual 1-3/8" six spline male shaft. **Max. Pump Speed - 540 RPM.**

MODEL	MAX. GPM	MAX. PSI	DESCRIPTION	HOSE BARB PORTS			WEIGHT (lbs.)	LIST PRICE
				IN	OUT	BYPASS		
BETA-150/CC 	42	700	Four diaphragm pump with pulsation dampener & control unit with adjustable pressure regulator, manual dump lever, dual ball valve outlets & pressure gauge. Has dual 1-3/8", 6-spline male PTO shaft. <i>For PTO safety shields, see page 27.</i>	1-1/2"	(2) 1/2" (1) 3/4" Male NPT (1) 3/4" Female NPT	1"	130	\$4,595.00

UDOR BETA Series Diaphragm Pumps

UDOR BETA Series pumps have brass heads, stainless steel and brass manifolds, steel connecting rods, mounting rails and a dual 1-3/8" six spline male shaft. **Max. Pump Speed - 540 RPM.**

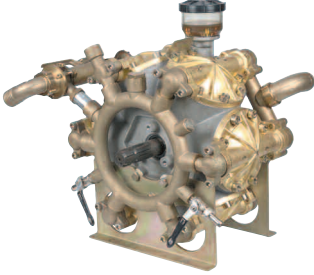
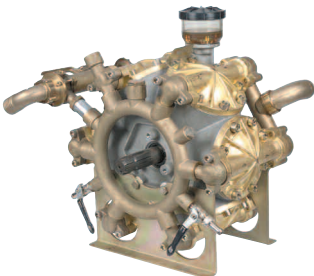
MODEL	MAX. GPM	MAX. PSI	DESCRIPTION	HOSE BARB PORTS			WEIGHT (lbs.)	LIST PRICE
				IN	OUT	BYPASS		
 BETA-200/CC	56	700	Six diaphragm pump with control unit with adjustable pressure regulator, manual dump lever, dual ball valve outlets & pressure gauge. Has dual 1-3/8", 6-spline male PTO shaft. <i>For PTO safety shields, see page 27.</i>	(2) 1-1/2"	(2) 1/2" (2) 3/4" <small>Female NPT</small>	1-1/4"	200	\$6,425.00
 BETA-240/CC	64	700	Six diaphragm pump with control unit with adjustable pressure regulator, manual dump lever, dual ball valve outlets & pressure gauge. Has dual 1-3/8", 6-spline male PTO shaft. <i>For PTO safety shields, see page 27.</i>	(2) 1-1/2"	(2) 1/2" (2) 3/4" <small>Female NPT</small>	1-1/4"	200	\$6,585.00

UDOR GAMMA SERIES PLUNGER PUMP FEATURES

- Large Capacity Vented Oil Bath Crank Case.
- Solid Ceramic Plungers.
- Stainless Steel Check Valves.
- High Strength Aluminum Alloy or Bronze Connecting Rods.
- Teflon Coated Body Guides for Optimum Piston Guide Support.
- Maximum Fluid Temperature, 160° F.
- Heat Treated Crank Shaft.
- Industrial Quality Tapered Roller Bearings.





UDOR GAMMA Series Plunger Pumps

For control unit options, see pages 35-39. **Max. Pump Speed - 600 RPM.**

MODEL	MAX. GPM	MAX. PSI	DESCRIPTION	HOSE BARB PORTS		WEIGHT (lbs.)	LIST PRICE
				IN	OUT		
 GAMMA-20B/GR-5	6	750	Three cylinder plunger pump with anodized aluminum crank case, brass head, solid ceramic plungers & gear reduction for 5-6.5 HP gasoline engines with 3/4" shafts.	1/2" <small>Female NPT</small>	(2) 3/8" <small>Female NPT</small>	35	\$1,140.00

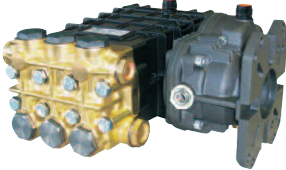
UDOR GAMMA Series Plunger Pumps

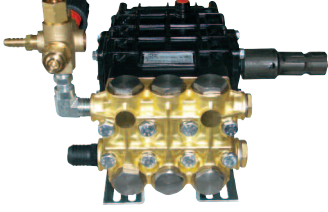
For control unit options, see pages 35-39. **Max. Pump Speed - 600 RPM.**

MODEL	MAX. GPM	MAX. PSI	DESCRIPTION	HOSE BARB PORTS		WEIGHT (lbs.)	LIST PRICE
				IN	OUT		
GAMMA-40B/GR-8 	10	750	Three cylinder plunger pump with anodized aluminum crank case, brass head, solid ceramic plungers & gear reduction for 8-9 HP gasoline engines with 1" shafts.	3/4" <small>Female NPT</small>	(2) 1/2" <small>Female NPT</small>	46	\$1,630.00
GAMMA-50B/GR-8 	13	750	Three cylinder plunger pump with anodized aluminum crank case, brass head, solid ceramic plungers & gear reduction for 8-9 HP gasoline engines with 1" shafts.	3/4" <small>Female NPT</small>	(2) 1/2" <small>Female NPT</small>	49	\$1,950.00
GKC-16/20-PTO 	4	3000	Three cylinder plunger pump with anodized aluminum crank case, brass head & solid ceramic plungers. Complete with mounting rails, unloader & 1-3/8", 6-spline male PTO shaft.	1"	(1) 3/8" <small>Female NPT</small>	45	\$1,790.00
GKC-50/12-PTO 	5.5	2500	Three cylinder plunger pump with anodized aluminum crank case, brass head & solid ceramic plungers. Complete with mounting rails, unloader & 1-3/8", 6-spline male PTO shaft.	1"	(1) 3/8" <small>Female NPT</small>	45	\$1,875.00
GAMMA-62/CC 	16	1000	Three cylinder plunger pump of anodized aluminum construction with ceramic plungers & dual 1-3/8", 6-spline male PTO shaft. <i>For control unit options, see pages 35-39.</i> <i>For PTO safety shields, see page 27.</i>	1-1/4"	(2) 3/4" <small>Female NPT</small> (2) 3/8" <small>Female NPT</small>	50	\$1,825.00
GAMMA-62/CC HYD 	16	1000	Three cylinder plunger pump of anodized aluminum construction with ceramic plungers, hydraulic motor & mounting kit. Hydraulic Requirements: 14 GPM 1400PSI <i>For control unit options, see pages 35-39.</i> <i>For PTO safety shields, see page 27.</i>	1-1/4"	(2) 3/4" <small>Female NPT</small> (2) 3/8" <small>Female NPT</small>	75	\$3,060.00





UDOR GAMMA Series Plunger Pumps

For control unit options, see pages 35-39. **Max. Pump Speed - 600 RPM.**

MODEL	MAX. GPM	MAX. PSI	DESCRIPTION	HOSE BARB PORTS		WEIGHT (lbs.)	LIST PRICE
				IN	OUT		
 GAMMA-62/GR	16	350 with 8-9 HP • 500 with 11-13 HP	GAMMA-62 pump with gear reduction for 8-13 HP gasoline engines with 1" shafts. <i>For control unit options, see pages 35-39. Thru shaft safety cover, part #1219.15, included.</i>	1-1/4"	(2) 3/4" Female NPT (2) 3/8" Female NPT	65	\$2,585.00
 GAMMA-62/GR-18	16	1000	GAMMA-62 pump with gear reduction for 16-20 HP gasoline engines with 1" shafts. <i>Recommended control unit #6005.15. Thru shaft safety cover, Part #1219.15, included.</i>	1-1/4"	(2) 3/4" Female NPT (2) 3/8" Female NPT	75	\$2,760.00
 GAMMA-62/TS	16	1000	Replacement pump for GAMMA-62/GR & GAMMA-62/GR-18.	1-1/4"	(2) 3/4" Female NPT (2) 3/8" Female NPT	55	\$1,950.00
 GAMMA-105/CC	28	850	Three cylinder plunger pump of anodized aluminum construction with solid ceramic plungers & dual 1-3/8", 6-spline male PTO shaft. <i>For PTO safety shields, see page 27. Recommended control unit #6005.15.</i>	1-1/4"	(2) 3/4" Female NPT (2) 3/8" Female NPT	85	\$3,230.00
 GAMMA-105/CC HYD	28	850	Three cylinder plunger pump of anodized aluminum construction with solid ceramic plungers, hydraulic motor & mounting kit. Hydraulic Requirements: 14 GPM 1800 PSI <i>For PTO safety shields, see page 27. Recommended control unit #6005.15.</i>	1-1/4"	(2) 3/4" Female NPT (2) 3/8" Female NPT	100	\$4,470.00
 GAMMA-202/CC	52	850	Six cylinder plunger pump of anodized aluminum construction with solid ceramic plungers & dual 1-3/8", 6-spline male PTO shaft. <i>For PTO safety shields, see page 27. Recommended control unit #6005.14.</i>	2"	(4) 3/4" Female NPT (4) 3/8" Female NPT	120	\$5,315.00

UDOR GAMMA Series Plunger Pumps

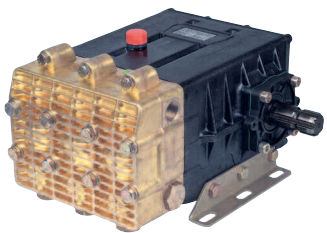
For control unit options, see pages 35-39. **Max. Pump Speed - 600 RPM.**

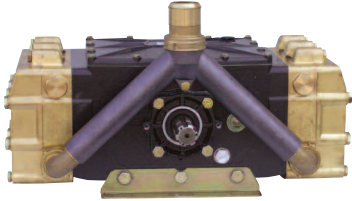
MODEL	MAX. GPM	MAX. PSI	DESCRIPTION	HOSE BARB PORTS		WEIGHT (lbs.)	LIST PRICE
				IN	OUT		
 GAMMA-202/TS-1C	52	850	Six cylinder plunger pump of anodized aluminum construction with brass heads, solid ceramic plungers & dual shafts (1) 1-3/8" 6-spline & (1) 35mm solid keyed shaft. <i>For PTO safety shields, see page 27.</i> <i>Recommended control unit #6005.14.</i>	2"	(4) 3/4" Female NPT (4) 3/8" Female NPT	160	\$6,590.00
 GAMMA-242/CC	62	700	Six cylinder plunger pump of anodized aluminum construction with solid ceramic plungers & dual 1-3/8", 6-spline male PTO shaft. <i>For PTO safety shields, see page 27.</i> <i>Recommended control unit #6005.14.</i>	2"	(4) 3/4" Female NPT (4) 3/8" Female NPT	120	\$5,475.00
 GAMMA-62B/CC	16	1500	Three cylinder plunger pump with anodized aluminum crank case, brass head & valve plate, solid ceramic plungers, stainless steel plunger guides, bronze connecting rods & dual 1-3/8", 6-spline male PTO shaft. <i>For PTO safety shields, see page 27.</i> <i>Recommended control unit UB150.</i>	1-1/4"	(2) 3/4" Female NPT (2) 3/8" Female NPT	80	\$4,460.00
 GAMMA-103B/CC	28	1500	Three cylinder plunger pump with anodized aluminum crank case, brass head & valve plate, solid ceramic plungers, stainless steel plunger guides, bronze connecting rods & dual 1-3/8", 6-spline male PTO shaft. <i>For PTO safety shields, see page 27.</i> <i>Recommended control unit UB150.</i>	1-1/4"	(2) 3/4" Female NPT (2) 3/8" Female NPT	105	\$4,835.00
 GAMMA-200B/CC	52	1200	Six cylinder plunger pump with anodized aluminum crank case, brass heads & valve plates, solid ceramic plungers, stainless steel plunger guides, bronze connecting rods & dual 1-3/8", 6-spline male PTO shaft. <i>For PTO safety shields, see page 27.</i> <i>Recommended control unit UB150.</i>	2"	(4) 3/4" Female NPT (4) 3/8" Female NPT	180	\$8,425.00

Industrial Hydraulic Wash Down Units

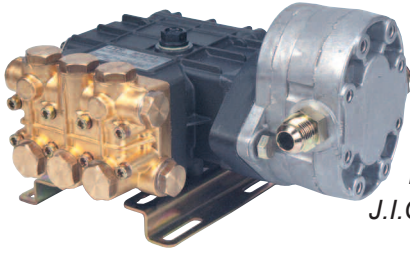

P-Series Industrial Hydraulic-Drive Plunger Pump

P-Series Pump with Mounting Rails, Heavy Duty Hydraulic Gear Motor with J.I.C. #10 Male Side Inlet & Outlet Fittings. Pressurized or Flooded Suction ONLY.

	MODEL	GPM	PSI	HYDRAULIC REQUIREMENTS	WEIGHT	LIST PRICE
Hydraulic Drive 1750 RPM	PND 3.0/20-ZH	3.0	1000	5 GPM @ 1400 PSI		
		3.0	1500	5 GPM @ 1800 PSI	24 lbs.	\$1,505.00
		3.0	2000	5 GPM @ 2200 PSI		

P-Series Industrial Hydraulic-Drive Plunger Pump Kit

Kit includes P-Series Hydraulic Drive Pump with Mounting Rails, Unloader, 3/4" Inlet Hose Barb, Hydraulic Motor, 14" x 20" Base Plate with Rubber Bumpers and Safety Pop-off. Pressurized or Flooded Suction ONLY.

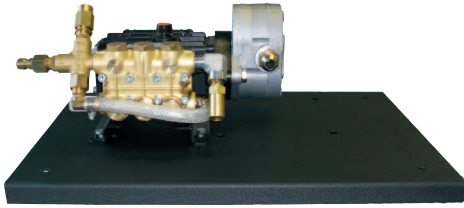

MODEL	SPECIFICATIONS	WEIGHT	LIST PRICE
PND 3.0/20-ZH/K	See Chart Above for Ratings & Hydraulic Requirements	45 lbs.	\$1,975.00

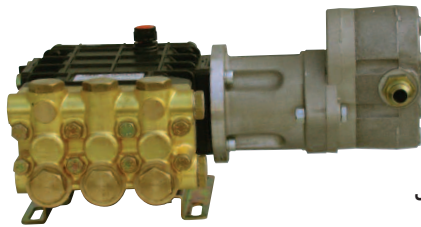

M-Series Industrial Hydraulic-Drive Plunger Pump

M-Series Pump with Mounting Rails, Heavy Duty Hydraulic Gear Motor with J.I.C. #10 Male Side Inlet & Outlet Fittings. Pressurized or Flooded Suction ONLY.

	MODEL	GPM	PSI	HYDRAULIC REQUIREMENTS	WEIGHT	LIST PRICE
Hydraulic Drive 1750 RPM	MD 4.0/30-SH	4.0	2000	12 GPM @ 1100 PSI		
		4.0	2500	12 GPM @ 1300 PSI	36 lbs.	\$1,930.00
		4.0	3000	12 GPM @ 1500 PSI		

M-Series Industrial Hydraulic-Drive Plunger Pump Kit

Kit includes M-Series Hydraulic Drive Pump with Mounting Rails, Unloader, 1" Inlet Hose Barb, Hydraulic Motor, 14" x 20" Base Plate with Rubber Bumpers, Thermal Relief Valve and Safety Pop-off. Pressurized or Flooded Suction ONLY.

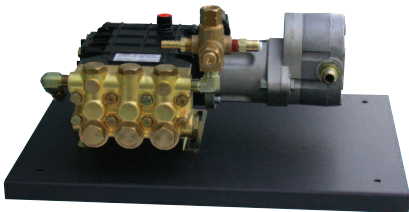

MODEL	SPECIFICATIONS	WEIGHT	LIST PRICE
MD 4.0/30-SH/K	See Chart Above for Ratings & Hydraulic Requirements	65 lbs.	\$2,395.00

UDOR LUBE Premium Pump Oil

MODEL	DESCRIPTION	LIST PRICE
 UDOR LUBE	15.5823 SAE 40W hydraulic lubricant specially formulated for use in diaphragm & plunger pumps. 1-Quart bottle SUPERIOR LUBRICATION <ul style="list-style-type: none"> • Non-detergent • Non-foaming • Resists Breakdown Due to Oxidation • Rust Inhibitors • Anti-wear Agents 	\$12.70
	15.5823/S COLD WEATHER synthetic formula. 1-Quart Bottle.	\$29.70

UDOR LUBE is also available in a case (12 1-Quart Bottles) Order Qty 12 - Part# 15.5823

UDOR Gear Reducer Kits

All UDOR gear reductions are black anodized, bearing supported and vented for long life and cooler operation.



MODEL	ENGINE BRAND/HORSEPOWER				FOR USE ON UDOR PUMP MODEL	LIST PRICE
	BRIGGS & STRATTON	VANGUARD	HONDA	KOHLER COMMAND		
5047.D7 3/4"	3, 3.5, 5 HP	•	4, 5.5 HP	•	KAPPA-15	\$177.70
5050.E2 5/8"	•	•	2.2, 2.5, 3 HP	•	KAPPA-15	\$177.70
5028.76 3/4"	3, 3.5, 5 HP	•	4, 5.5 HP	•	IOTA-17	\$335.20
5035.74 5/8"	•	•	2.2, 2.5, 3 HP	•	IOTA-17	\$335.20
5027.75 3/4"	3.5, 5, 5.5, 6.5 HP	6 HP	4, 5.5, 6.5 HP	6 HP	KAPPA-30/40/55, RO-70, RO-110, ZETA-40/85	\$521.50
5033.A4 1"	8 HP	9, 11, 13 HP	8, 9, 11, 13 HP	11, 14 HP	RO-70/110, KAPPA-55/75	\$648.50
5053.E5 1"	8 HP	9, 11, 13 HP	8, 9, 11, 13 HP	11, 14 HP	GAMMA-60/62	\$648.50
5034.B5 1"	16, 18 HP	16, 18, 20 HP	18, 20 HP	18, 20, 22 HP	KAPPA-100, 120	\$892.40
5063.B5 1"	16, 18 HP	16, 18, 20 HP	18, 20 HP	18, 20, 22 HP	GAMMA-60/62	\$892.40
5071.75 3/4"	3.5, 5 HP	6 HP	4, 5.5, 6.5 HP	6 HP	KAPPA-33/43/53	\$521.50
5085.F7 3/4"	3.5, 5, 5.5, 6.5 HP	6 HP	4, 5.5, 6.5 HP	6 HP	KAPPA-25	\$355.30
5091.D9 5/8"	•	•	2.2, 2.5, 3 HP	•	IOTA-20	\$335.20
5094.76 3/4"	3.5, 5 HP	6 HP	4, 5.5, 6.5 HP	6 HP	IOTA-20	\$335.20
5096.B5 1-1/8"	•	25-36 HP	24-27 HP	25-35 HP	KAPPA-150	\$1,060.70
 5102.G2	P.T.O. step up gear box multiplier with 1-3/8" six spline male shaft. Designed to mount to M, MK, G and GK-Series 1450 RPM UDOR plunger pumps. 540 RPM input = 1450 RPM output.					\$705.00

FOR ENGINES NOT LISTED, CONSULT UDOR USA.

UDOR Shaft Adapter Kits



7750.31*

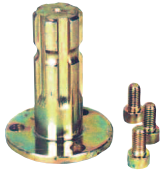

7753.A6*

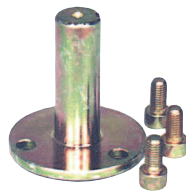

7751.A3*



7702.01

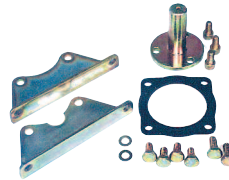

7751.A9



7752.A2***

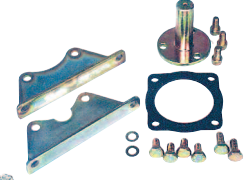

7751.A1*

MODEL	DESCRIPTION	FOR USE ON UDOR PUMP #	LIST PRICE
7750.31*	3/4" Solid Shaft	IOTA-17/20**	\$112.90
7751.A3*	1" Solid Shaft	IOTA-17/20**, RO-110, KAPPA-55/75/100, ZETA-40/85	\$112.90
7751.A9	3/4" Solid Shaft with Mounting Rails	KAPPA-30/40	\$141.90
7751.A1*	1" Solid Shaft with Mounting Rails	RO-70, KAPPA-30/40	\$141.90
7753.A6	1-3/8", 6-spline Male PTO Shaft	RO-110, KAPPA-55/75/100, ZETA-40/85	\$112.90
7702.01	1-3/8", 6-spline male PTO shaft w/ mounting rails & safety shield	RO-70, KAPPA-30/40	\$164.90
7752.A2***	1-3/8", 6-spline female PTO cplr. w/ torque arms, chain & safety shield	IOTA-17/20**, RO-70, KAPPA-30/40/55/75, ZETA-40/85	\$193.70

* When using these shafts for PTO applications, safety shield (part # 1219.02) MUST be used. For PTO safety shields, see page 27.

** When using these shafts with IOTA-17/20 pumps, crankshaft adapter # 0501.05 is required. Please order separately.

*** When mounting shaft adapter kit 7752.A2 on IOTA-17/20 pump, bolt kit #BK-17 is required. Please specify.

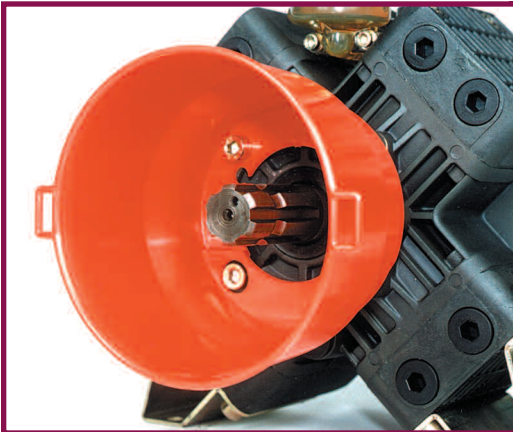

FOR YOUR PROTECTION, WE RECOMMEND SAFETY SHIELDS FOR ALL PTO DRIVE & THRU SHAFT APPLICATIONS.

For Male PTO drive applications order Part # 1219.02

For Female PTO drive applications order Part # 1219.04

For Male Thru-shaft protection. order Part # 1219.15

*For RO-110/C, RO-130/C,
ZETA-85/C & ZETA-100/C pumps order Part # 1219.25*

Hydraulic Requirements for UDOR Pumps

PUMP MODEL	HYDRAULIC MOTOR	HYDRAULIC FLOW	HYDRAULIC PRESSURE
KAPPA-30/40	OMP-50	8 GPM	800 PSI
RO-70, ZETA-40E, ZETA-40/P, ZETA-85	OMP-50	8 GPM	800 PSI
KAPPA-55, RO-125HYDK	OMP-50	8 GPM	1000 PSI
RO-110, RO-130/C, RO-175/HYDK	OMP-100	14 GPM	1000 PSI
KAPPA-75/100, RO-160/HYD	OMP-100	14 GPM	1200 PSI
RO-250/HYD, KAPPA-120	OMP-100	14 GPM	1600 PSI
GAMMA-62/CC	OMP-100	14 GPM	1400 PSI
GAMMA-100/CC	OMP-100	14 GPM	1800 PSI
GAMMA-105/CC	OMP-100	14 GPM	1800 PSI

UDOR Hydraulic Drive Components

MODEL	DESCRIPTION	LIST PRICE
 <p>OMP-50</p>	<p>Heavy duty hydraulic gear motor with 2-bolt, A-Mount flange, 1/2" female top ports & 1" solid, keyed shaft.</p> <p><i>To drive KAPPA-30/40 & RO-70, use mounting kit #4155.00/R.</i></p> <p><i>To drive ZETA-40E, ZETA-40/P, ZETA-85, ZETA-85/P, KAPPA-55, use mounting kit #4155.01.</i></p>	\$600.40
 <p>OMP-100</p>	<p>Heavy duty hydraulic gear motor with 2-bolt, A-Mount flange, 1/2" female top ports & 1" solid, keyed shaft. Mounts directly to RO-160/HYD, RO-175/HYD & RO-250/HYD pumps.</p> <p><i>To drive KAPPA-75/100, use mounting kit #4155.00.</i></p> <p><i>To drive KAPPA-120 or RO-110, use mounting kit #4155.01.</i></p> <p><i>To drive GAMMA-62/CC, GAMMA-100/CC or GAMMA-105/CC, use mounting kit #4155.02.</i></p> <p><i>To drive RO-110/C or RO-130/C, use mounting kit 4155.03</i></p>	\$630.20
 <p>4155.00</p>	<p>Hydraulic motor mounting kit with 2-bolt, A-Mount hydraulic motor mounting flange, 1" female keyed shaft & mounting bolts.</p> <p><i>Fits: KAPPA-75 & KAPPA-100.</i></p>	\$179.20
 <p>4155.00/R</p>	<p>Hydraulic motor mounting kit with 2-bolt, A-Mount hydraulic motor mounting flange, 1" female keyed shaft, pump rails & mounting bolts.</p> <p><i>Fits: KAPPA- 30/40 & RO-70.</i></p>	\$238.40
 <p>4155.01</p>	<p>Hydraulic motor mounting kit with 2-bolt, A-Mount hydraulic motor mounting flange, 1" female keyed shaft & mounting bolts.</p> <p><i>Fits: ZETA-40E, ZETA-40/P, ZETA-85, ZETA-85/P, KAPPA-55/120 & RO-110.</i></p>	\$179.20
 <p>4155.02</p>	<p>Hydraulic motor mounting kit with 2-bolt, A-Mount hydraulic motor mounting flange, 1" female keyed shaft & mounting bolts.</p> <p><i>Fits: GAMMA-62/CC, GAMMA-100/CC & GAMMA-105/CC.</i></p>	\$266.20
 <p>4155.03</p>	<p>Hydraulic motor mounting kit with 2-bolt, A-Mount hydraulic motor mounting flange, 1" female keyed shaft & mounting bolts.</p> <p><i>Fits: RO-110/C & RO-130/C.</i></p>	\$238.40

Electric Clutch Drive Assembly

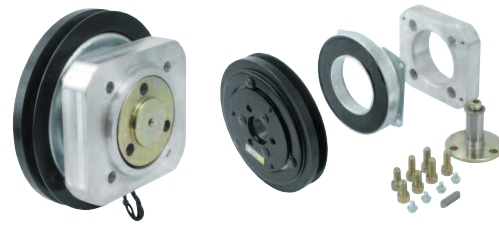

MODEL	DESCRIPTION	LIST PRICE
7750.01	12-volt Clutch Kit with 7" Single Groove Pulley with "A" Section Belt Groves for KAPPA-55/75/100 & RO-110.	\$863.70
7750.02	12-volt Clutch Kit with 7" Double Groove Pulley with "A" Section Belt Groves for KAPPA-55/75/100 & RO-110.	\$967.50
5214.91	12-volt Replacement Clutch 7" Single Groove.	\$602.30
5228.50	12-volt Replacement Clutch 7" Double Groove.	\$641.20

Drive Components & Safety Shields

FOR YOUR SAFETY, PTO SAFETY SHIELDS ARE RECOMMENDED FOR ALL PTO DRIVE APPLICATIONS.



10Q1



10Q2



0632.15



CD 5/8x3/4
CD 15/16x3/4
CD 3/4x1



CD 1x1
CD 1-3/8x1
CD 1-3/8x1-3/8

MODEL	DESCRIPTION	LIST PRICE
10H6	1-3/8", 6-spline H bushing for pulley driving pumps with 1-3/8", 6-spline male PTO shafts. For use with pulleys up to 2 grooves.	\$31.10
10H24	24mm H bushing for driving misc. pumps.	\$22.50
10H25	25mm H bushing for pulley driving KAPPA-25/33/43/53 pumps.	\$22.50
10Q1	1-3/8", 6-spline Q bushing for pulley driving pumps with 1-3/8", 6-spline male PTO shafts. For use with pulleys up to 3 grooves.	\$84.30
10Q135	35mm Q bushing for driving misc. pumps	\$84.30
10Q2	1-3/8", 6-spline Q bushing for pulley driving pumps with 1-3/8", 6-spline male PTO shafts. For use with pulleys up to 5 grooves.	\$90.10
CD 5/8x3/4	5/8" female x 3/4" female chain drive coupler assembly for driving 540 RPM male 5/8" solid shaft pumps with 6:1 gear reduced gas engine.	\$160.70
CD 15/16x3/4	15/16" female x 3/4" female chain drive coupler assembly for driving 540 RPM male 15/16" solid shaft pumps with 6:1 gear reduced gas engine.	\$160.70
CD 3/4x1	3/4" female x 1" female chain drive coupler assembly for driving 540 RPM male 3/4" solid shaft pumps with 6:1 gear reduced gas engines.	\$160.70
CD 1x1	1" female x 1" female chain drive coupler assembly for driving 540 RPM male 1" solid shaft pumps with 6:1 gear reduced gas engines.	\$160.70
CD 1-3/8x1	1-3/8", 6-spline female x 1" female chain drive coupler assembly for driving 540 RPM male 1-3/8", 6-spline pumps with 6:1 gear reduced gas engines.	\$160.70
CD 1-3/8x1-3/8	1-3/8", 6-spline female x 1-3/8", 6-spline female chain drive coupler assembly for driving 540 RPM male 1-3/8", 6-spline pumps with 1-3/8", 6-spline male PTO shaft.	\$160.70
0632.15	Coupler set, 1-3/8" six spline x 1-1/4" for driving diaphragm or plunger pumps with hydraulic motors or truck P.T.O.	\$209.00

Drive Components & Safety Shields

FOR YOUR SAFETY, PTO SAFETY SHIELDS ARE RECOMMENDED FOR ALL PTO DRIVE APPLICATIONS.



MODEL	DESCRIPTION	LIST PRICE
0005.22	1-3/8", 6-spline male PTO by 25mm female adapter to convert KAPPA-40/TS & KAPPA-55/TS pumps to 1-3/8", 6-spline male PTO.	\$82.70
1219.02	PTO safety shield for UDOR diaphragm & GAMMA-series plunger pumps. Includes mounting bolts.	\$27.70
1219.04	PTO safety shield for UDOR female PTO Kit #7752.A2.	\$27.70
1219.15	Shaft protector for UDOR diaphragm & GAMMA-series plunger pumps with thru shaft. Includes mounting bolts.	\$16.20
1219.25	Shaft protector for UDOR RO-110/C, RO-130/C & ZETA-85/C diaphragm pumps. Includes mounting bolts.	\$30.20
6914.83	1/4" x 2-1/4" engine key heat treated for use on 8-35 HP gas engines.	\$7.70
6921.91	3/16" x 1-3/4" engine key heat treated for use on 2.5 - 6.5 HP gas engines.	\$6.20

UDOR Pulsation Dampeners



MODEL	MAX. GPM	MAX. PSI	DESCRIPTION	LIST PRICE
6031.09	40	400	Plasticized aluminum pulsation dampener with 3/4" BSP male inlet. <i>Standard on RO-110, RO-110/C RO-130/C, RO-160/C, RO-160/CC & RO-160/HYD.</i>	\$221.20
6031.09E	40	400	Plasticized aluminum pulsation dampener with 3/4" NPT female inlet.	\$237.10
6031.02	52	850	Brass pulsation dampener with 3/4" BSP male inlet. <i>Standard on BETA-110, BETA-150, KAPPA-100, KAPPA-120, KAPPA-150 OMEGA-140/170 pumps.</i>	\$390.90

UDOR Column Sprayer

Master on/off valve is required in feed line to spray column.

MODEL	MAX. GPM	MAX. PSI	DESCRIPTION	LIST PRICE
 Shown Assembled	50*	850	1238.G3 - Brass Spray Column Holds up to 5 column mounted spray guns. <i>* Flow rate is dependent on number of spray guns attached.</i>	\$136.30
			1238.G4 - Column Mounted Spray Gun Spray gun with regulating lever to adjust spray pattern from straight stream to cone mist. Spherical ball mount allows full 360° rotation. Works well for orchard, vineyard, tree & roadside spraying.	\$138.60

UDOR Trigger Valves



MODEL	MAX. GPM	MAX. PSI	DESCRIPTION	LIST PRICE
 1238.M8	5	300	UDOR Polypropylene Trigger Valve with 3/8" hose barb inlet & 1/4" female NPT outlet. Includes serviceable filter screen in handle. Provides an excellent means for fabricating a custom spray gun assembly.	\$35.00
			Repair Kit Part # 8711.03	\$23.30
 23.208.84	18	700	UDOR nickel plated aluminum trigger valve with 1/2" female inlet & outlet ports & stainless steel trigger provides an excellent means for fabricating a custom spray gun assembly.	\$56.50
			Repair Kit Part # 8711.03	\$23.30
 15.0003.13	18	400	UDOR reinforced polypropylene trigger valve with stainless steel ball & spring and 1/2" female inlet & outlet ports. Provides an excellent means for fabricating a custom spray gun assembly.	\$41.10
			Repair Kit Part # 8711.07	\$20.50
 29.1903.7	18	700	UDOR reinforced polypropylene trigger valve with 1/2" female inlet & outlet ports. Provides an excellent means for fabricating a custom spray gun assembly.	\$47.90
			Repair Kit Part # 8711.03	\$23.30
 1215.18	10	4000	UDOR high pressure trigger valve with 3/8" female swivel inlet & 1/4" female outlet.	\$57.80
			Repair Kit Part # 1215.18K	\$30.60
 1215.28	5	2000	UDOR medium pressure trigger valve with 1/4" male inlet & 1/4" female outlet.	\$27.20
 ST-3002	25	7000	UDOR high pressure trigger valve with 1/2" female inlet & 1/2" female outlet.	\$518.80
			Repair Kit Part # ST3002K	\$108.00
 1215.29	16	350	UDOR heavy duty spray gun features adjustable spray pattern from straight stream up to a 60° cone mist. Ergonomic hand grip and trigger guard. Works well for wash down, de-icing and grass fire fighting.	\$159.00

UDOR Spray Guns

For spray tip performance charts, see page 32.

MODEL	MAX. GPM	MAX. PSI	DESCRIPTION	LIST PRICE
4.802.30 	5	300	UDOR spot spray gun with 28" wand & spray shield with 8002 spray tip.	\$110.90
			Repair Kit Part # 8711.03	\$23.30
35.901.16 (ECONOMY) 	5	600	UDOR economy spray gun with 7" barrel. Adjustable spray pattern from straight stream to cone mist.	\$114.30
2.3 Tip STD			Repair Kit Part # 35.302.18	\$20.50
26.901.162 (TURBO) 	15	850	UDOR high performance spray gun with 8" barrel. Adjustable spray pattern from straight stream to cone mist.	\$164.90
2.3 Tip STD			Repair Kit Part # 8711.03	\$23.30
26.901.400 (TURBO INDUSTRIAL) 	15	850	UDOR high performance spray gun with 8" barrel. Nickel plated aluminum trigger valve with stainless steel trigger and guard. Includes a 1/2" MBSP Inlet swivel. Adjustable spray pattern from straight stream to cone mist.	\$179.00
2.3 Tip STD			Repair Kit Part # 8711.03	\$23.30
7.901.103 (TURBINE) 	25	850	UDOR high performance spray gun with 17" barrel features 10 mm internal tubing & adjustable spray pattern from straight stream to cone mist.	\$224.20
4.5 Tip STD			Repair Kit Part # Kit 10/11	\$27.70
13.901.151 (LONG RANGE) 	30	850	UDOR high performance spray gun with 21" barrel features 12 mm internal tubing with stream straightener & adjustable spray pattern from straight stream to cone mist.	\$313.60
3.5 Tip STD			Repair Kit Part # Kit 10/11	\$27.70
37.901.20 (FOAM SPRAY GUN) 	13	3000	UDOR high performance foam spray gun with 21" barrel features 10 mm internal tubing, stream straightener and Venturi foam nebulizer. Adjustable spray pattern from straight stream to cone mist.	\$648.60

UDOR Spray Guns

MODEL	MAX. MAX.		DESCRIPTION	LIST PRICE
	GPM	PSI		
 22.901.161 (HIGH PRESSURE) 1.8 Tip STD	10	3000	UDOR high pressure, high performance spray gun with 21" barrel. Adjustable spray pattern from straight stream to cone mist.	\$320.70
			Repair Kit Part # 1215.18K	\$30.60
 22.901.163 (HIGH PRESSURE) 3.0 Tip STD	25	3000	UDOR high pressure, high performance spray gun with 21" barrel. Adjustable spray pattern from straight stream to cone mist.	\$671.60
			Repair Kit Part # Kit ST3002K	\$108.00

*UDOR Spray Gun Assemblies have a Polypropylene Trigger Valve with 3/8" hose barb inlet, serviceable filter screen in handle, stainless steel spray wand and brass adjustable nozzle or 11/16 x 16 male adapter. **300 PSI Max.***



NOTE - For spray gun with curved wand, add 'WB' to end of model #.

MODEL	MAX. GPM	MAX. PSI	SPRAY WAND LENGTH	ADJUSTABLE SPRAY TIP	SPRAY ADAPTER 11/16 X 16	LIST PRICE
4.802.14	5	300	20"	♦		\$59.60
4.802.18	5	300	20"		♦	\$63.80
4.802.24	5	300	28"	♦		\$65.30
4.802.20	5	300	28"		♦	\$71.00
Repair Kit Part # 8711.03						\$23.30

*UDOR Spray Gun Assemblies have a Brass Trigger Valve with 1/4" MNPT inlet, stainless steel spray wand and brass adjustable nozzle or 11/16 x 16 male adapter. **300 PSI Max.***



NOTE - For spray gun with curved wand, add 'WB' to end of model #.

MODEL	MAX. GPM	MAX. PSI	SPRAY WAND LENGTH	ADJUSTABLE SPRAY TIP	SPRAY ADAPTER 11/16 X 16	LIST PRICE
5.803.30	5	300	20"	♦		\$56.60
5.803.34	5	300	20"		♦	\$60.80
5.803.40	5	300	28"	♦		\$62.20
5.803.36	5	300	28"		♦	\$67.50

UDOR Spray Gun Swivels



26.1502.45



9016F6M



9018F8M



9018F8M/T

MODEL	DESCRIPTION	LIST PRICE
26.1502.45	Brass Swivel. 3/8" FBSP by 3/8" MBSP. Fits both Standard Turbo Gun and Industrial Turbo Gun. Max. 1000 PSI.	\$22.90
9016F6M	Brass Swivel. 3/8" FNPT by 3/8" MNPT. For any 3/8" swivel application. Max. 1000 PSI.	\$22.90
9018F8M	Brass Swivel. 1/2" FNPT by 1/2" MNPT. For Turbo Spray Gun or other 1/2" swivel application. Max. 1000 PSI.	\$26.20
9018F8M/T	Brass Swivel. 1/2" Female Metric thread by 1/2" MNPT. For Turbine & Long Range Spray Guns. Max. 1000 PSI.	\$28.40

UDOR Hose Reel Swivels



2302.66



2505.88



2506.88

MODEL	DESCRIPTION	LIST PRICE
2302.66	3/8" male NPT by 3/8" female NPT heavy duty 90° high pressure hose reel swivel. Max. 4000 PSI.	\$70.90
2505.88	1/2" female NPT by 1/2" female NPT heavy duty 90° high pressure hose reel swivel. Max. 4000 PSI.	\$75.30
2506.88	1/2" male NPT by 1/2" female NPT heavy duty 90° high pressure hose reel swivel. Max. 4000 PSI.	\$75.30
2300.RK	3/8" Swivel Repair Kit.	\$26.20
2500.RK	1/2" Swivel Repair Kit.	\$28.20

UDOR Easy Turn Hose Barb Swivels

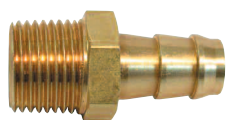

7016.00

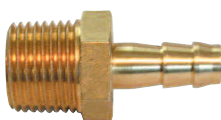

7016.01

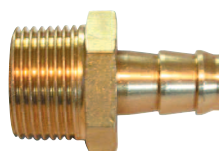

7016.02

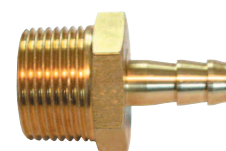

7016.03

MODEL	DESCRIPTION	LIST PRICE
7016.00	Brass Hose Barb Swivel. 1/2" male NPT by 1/2" hose barb. Max. 350 PSI.	\$21.80
7016.01	Brass Hose Barb Swivel. 1/2" male NPT by 3/8" hose barb. Max. 350 PSI.	\$21.80
7016.02	Brass Hose Barb Swivel. 3/4" male NPT by 1/2" hose barb. Max. 350 PSI.	\$24.80
7016.03	Brass Hose Barb Swivel. 3/4" male NPT by 3/8" hose barb. Max. 350 PSI.	\$24.80

UDOR Spray Tip Performance Charts



High Performance Spray Guns & Column Sprayer

Gallons Per Minute / Maximum Spray Distance in Feet

MODEL	ORIFICE (MM)	MATERIAL	100 PSI	200 PSI	400 PSI	600 PSI	800 PSI	LIST PRICE
68.1802.51	1.5	Ceramic	.78 / 17	1.1 / 20	1.5 / 23	1.8 / 25	2.1 / 27	\$13.10
68.1802.52	1.8	Ceramic	1.1 / 19	1.6 / 21	2.3 / 24	2.6 / 26	2.9 / 28	\$13.10
68.1802.53	2.0	Ceramic	1.4 / 21	2.0 / 24	2.8 / 26	3.4 / 29	3.8 / 32	\$13.10
68.1802.54	2.3	Ceramic	2.0 / 24	2.5 / 29	4.0 / 34	5.0 / 42	5.5 / 45	\$13.10
68.1802.16	2.5	Ceramic	2.5 / 23	3.0 / 28	4.5 / 32	5.5 / 40	6.5 / 44	\$13.10
68.1802.17	3.0	Ceramic	3.0 / 28	4.5 / 29	6.5 / 34	8.0 / 41	9.0 / 44	\$13.10
13.1802.73	3.5	S/S	4.5 / 31	6.0 / 36	8.5 / 41	11.0 / 50	12.0 / 54	\$21.80
13.1802.58	4.0	S/S	5.0 / 35	7.5 / 38	10.0 / 43	13.5 / 53	14.5 / 59	\$21.80
13.1802.59	4.5	S/S	6.5 / 37	9.0 / 39	12.5 / 44	16.5 / 54	18.0 / 62	\$21.80
13.1802.60	5.0	S/S	7.5 / 33	10.0 / 41	14.0 / 47	18.5 / 59	21.0 / 67	\$21.80
13.1802.61	5.5	S/S	8.0 / 35	11.5 / 42	16.0 / 47	21.0 / 59	23.0 / 70	\$21.80
13.1802.75	6.0	S/S	9.0 / 38	12.5 / 44	18.0 / 54	23.0 / 66	26.0 / 74	\$21.80
13.1802.74	7.0	S/S	9.5 / 21	13.5 / 47	19.0 / 57	24.0 / 70	27.0 / 77	\$21.80



High Pressure Spray Guns

Gallons Per Minute

MODEL	ORIFICE (MM)	MATERIAL	1000 PSI	1500 PSI	2000 PSI	2500 PSI	3000 PSI	LIST PRICE
68.1802.50	1.2	Ceramic	2.0	2.4	2.6	2.9	3.5	\$13.10
68.1802.51	1.5	Ceramic	2.5	3.0	3.5	3.9	4.4	\$13.10
68.1802.52	1.8	Ceramic	3.5	4.1	4.7	5.3	5.9	\$13.10
68.1802.53	2.0	Ceramic	4.5	5.1	5.8	6.2	6.8	\$13.10
68.1802.54	2.3	Ceramic	6.0	7.0	8.0	9.0	10.0	\$13.10
68.1802.16	2.5	Ceramic	7.5	9.0	10.5	11.5	13.0	\$13.10
68.1802.17	3.0	Ceramic	10.0	12.0	14.0	16.0	18.0	\$13.10
13.1802.73	3.5	S/S	13.0	16.0	19.0	22.0	26.0	\$21.80







Economy Spray Guns

Gallons Per Minute / Maximum Spray Distance in Feet

MODEL	ORIFICE (MM)	40 PSI	100 PSI	200 PSI	300 PSI	400 PSI	500 PSI	LIST PRICE
61.1802.47	1.5	.50 / 14	.78 / 17	1.1 / 20	1.3 / 22	1.5 / 23	1.7 / 24	\$11.80
61.1802.48	1.8	.70 / 17	1.1 / 19	1.6 / 21	1.9 / 23	2.3 / 24	2.5 / 26	\$11.80
61.1802.55	2.0	.89 / 19	1.4 / 21	2.0 / 24	2.5 / 24	2.8 / 26	3.2 / 27	\$11.80
61.1802.68	2.3	1.3 / 22	2.0 / 24	2.8 / 24	3.4 / 26	4.0 / 27	4.4 / 29	\$11.80



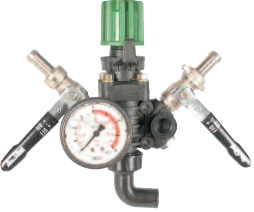

UDOR Pump Mounted Control Units

Specifically designed for use on UDOR Diaphragm Pumps.

MODEL	MAX. GPM	MAX. PSI	DESCRIPTION	LIST PRICE
6010.23 	5	275	Pump mounted control with adjustable pressure regulator & manual dump lever. 3/8" hose barb discharge port. Control is used for all IOTA-17, 18, 20 series pumps.	\$123.00
			Repair Kit Part #8701.01	\$22.30
6005.31 	30	600	Pressure regulator with manual dump lever, 1/4" gauge port, 3/4" male BSP inlet port & 3/4" hose barb bypass port. For use on GAMMA-62 pumps.	\$179.20
			Repair Kit Part #8701.25	\$59.60
6005.31/LP 	30	350	Pressure regulator with manual dump lever, 1/4" gauge port, 3/4" male BSP inlet port & 3/4" hose barb bypass port. For use on GAMMA-62 pumps.	\$179.20
			Repair Kit Part #8701.25	\$59.60
6010.24 	20	560	Pump or remote mounted control with adjustable pressure regulator with manual dump lever. Includes two 1/2" ball valve discharge ports & pressure gauge. Control is standard on KAPPA-40/55.	\$221.20
			Repair Kit Part #8701.10	\$59.60
6010.24/LP 	20	350	Same as 6010.24 except regulator is fitted with a lighter spring & gauge for lower pressure applications. Control is standard on KAPPA-30 & KAPPA-55/GR5.	\$221.20
			Repair Kit Part #8701.10	\$59.60
6010.93 	22	560	Pump or remote mounted control with right angle entry from main body to adjustable pressure regulator for smoother operation & longer life. Includes manual dump lever, two 1/2" ball valve discharge ports & pressure gauge. Standard on KAPPA-33, KAPPA-43 & KAPPA-53.	\$221.20
			Repair Kit Part #6062.A9	\$59.60

UDOR Pump Mounted Control Units

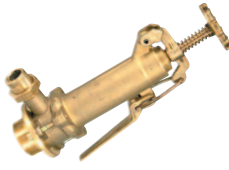
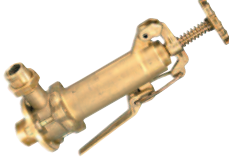

Specifically designed for use on UDOR Diaphragm Pumps.

MODEL	MAX. GPM	MAX. PSI	DESCRIPTION	LIST PRICE
 <p>6010.95</p>	22	350	Same as 6010.93 except regulator is fitted with a lighter spring & gauge for lower pressure applications. Standard on KAPPA-25, ZETA-40E, ZETA-40E/GR, ZETA-85, ZETA-85/GR-5.	\$221.20
			Repair Kit Part #6062.A9	\$59.60
 <p>6010.96</p>	22	350	Same as 6010.95 except regulator is fitted with a heat treated stainless steel poppet & seat, poly discharge plug & stainless mounting bolts. Standard on ZETA-40P, ZETA-40P/GR, ZETA-85P & ZETA-85P/GR-5.	\$244.80
			Repair Kit Part #6062.A9	\$59.60
 <p>6047.06</p>	26	560	Pump or remote mounted control with right angle entry from main body to adjustable pressure regulator for smoother operation & longer life. Includes manual dump lever, two 1/2" ball valve discharge ports & pressure gauge. Standard on KAPPA-75 & KAPPA-100.	\$287.60
			Repair Kit Part #8701.02	\$59.60
 <p>6047.06/LP</p>	26	350	Same as 6047.06 except regulator is fitted with a lighter spring & gauge for lower pressure applications. Control is recommended for RO-70 & RO-70/GR-5.	\$287.60
			Repair Kit Part #8701.02	\$59.60
 <p>6005.14</p>	64	1000	High volume adjustable brass pressure regulator with master on/off lever, 3/4" male BSP inlet port, 1/4" gauge port & 1-1/4" hose barb bypass port. Standard on BETA-200/240 pumps. For use with GAMMA-200/202/242 pumps.	\$382.30
			Repair Kit Part #8701.03	\$100.40
 <p>6005.15</p>	45	1000	High volume adjustable brass pressure regulator with master on/off lever, 3/4" male BSP inlet port, 1/4" gauge port & 1" hose barb bypass port. Standard on BETA -110/150, OMEGA-140/170 & KAPPA-120/150 pumps. For use with GAMMA-62/95/100/105 pumps.	\$364.80
			Repair Kit Part #8701.03	\$100.40



UDOR Pump Mounted Control Units

MODEL	MAX. GPM	MAX. PSI	DESCRIPTION	LIST PRICE
 6047.06/IND	26	560	Pump or remote mounted control with right angle entry from main body to adjustable pressure regulator for smoother operation & longer life. Includes manual dump lever, 3/4" FNPT discharge port, straight steel bypass barb & pressure gauge. Standard on KAPPA-100/C IND.	\$343.50
			Repair Kit Part #8701.02	\$59.60







UDOR Control Unit Remote Mounting Kits

MODEL	DESCRIPTION	LIST PRICE
 7704.05	For use with KAPPA-40/TS, 55/TS, 75/TS & 100/TS or with standard pumps for remote mounting of 6010.24/LP, 6047.06/LP or 6010.95 control units. Kit includes 3/4" hose barb outlet for pump & a 3/4" hose barb inlet for control unit. Max. 350 PSI.	\$61.00
 7704.07	For use with KAPPA-40/TS 55/TS, 75/TS & 100/TS or with standard pumps for remote mounting of 6010.24, 6047.06 or 6010.93 control units. Kit includes 3/4" male NPT outlet for pump & a 3/4" female NPT inlet for control unit. Max. 560 PSI.	\$89.80
 7705.00	This billet aluminum mounting block can be used to mount pressure regulators, pulsation dampeners, ball valves & pressure gauges away from the pump location for safer more convenient operation. Has 3 - 3/4" female NPT ports, 3 - 1/2" female NPT ports, 1 - 1/4" female NPT port & 4 - 5/16"-18 mounting holes. Dimensions - 7.25" L x 2" W x 2" H. Max. 2000 PSI. <i>Also for use with standard pumps for remote mounting of control units.</i>	\$166.30

UDOR Universal Control Units

MODEL	MAX. GPM	MAX. PSI	DESCRIPTION	LIST PRICE
 6005.31/N	30	600	Pressure regulator with manual dump lever, 1/4" gauge port, 3/4" male NPT inlet port & 3/4" hose barb bypass port.	\$193.70
			Repair Kit Part #8701.25	\$59.60
 6005.31/LP-N	30	350	Pressure regulator with manual dump lever, 1/4" gauge port, 3/4" male NPT inlet port & 3/4" hose barb bypass port.	\$193.70
			Repair Kit Part #8701.25	\$59.60

UDOR Universal Control Units







MODEL	MAX. GPM	MAX. PSI	DESCRIPTION	LIST PRICE
 6004.05	32	600	Remote mounted control with adjustable pressure regulator & master on/off lever, 3/4" hose barb inlet, 1" hose barb bypass, two 1/2" ball valve discharge ports & two 3/8" female accessory ports.	\$455.20
			Repair Kit Part #6062.56	\$66.60
 6010.25	20	350	Pump mounted Universal Control Unit with adjustable pressure regulator & manual dump lever with 3/4" female NPT inlet port. Includes two 1/2" ball valve discharge ports & pressure gauge. For use with diaphragm, plunger, piston or roller pumps.	\$238.40
			Repair Kit Part #8701.10	\$59.60
 6010.25/HP	20	560	Pump mounted Universal Control Unit with adjustable pressure regulator & manual dump lever with 3/4" female NPT inlet port. Includes two 1/2" ball valve discharge ports & pressure gauge. For use with diaphragm, plunger, piston or roller pumps.	\$238.40
			Repair Kit Part #8701.10	\$59.60
 6010.26	20	350	Remote mounted Universal Control Unit with adjustable pressure regulator & manual dump lever with 3/4" hose barb inlet port. Includes two 1/2" ball valve discharge ports & pressure gauge. For use with diaphragm, plunger, piston or roller pumps.	\$238.40
			Repair Kit Part #8701.10	\$59.60
 6010.26/HP	20	560	Remote mounted Universal Control Unit with adjustable pressure regulator & manual dump lever with 3/4" hose barb inlet port. Includes two 1/2" ball valve discharge ports & pressure gauge. For use with diaphragm, plunger, piston or roller pumps.	\$238.40
			Repair Kit Part #8701.10	\$59.60
 6010.93/FH	20	560	Pump mounted control unit with right angle entry from main body to adjustable pressure regulator for smoother operation and longer life. Includes manual dump lever, two 1/2" ball valve discharge ports and pressure gauge. <i>Direct replacement for GS40GI on D30 & D50 pumps.</i>	\$246.20
			Repair Kit Part #6062.A9	\$59.60

UDOR Universal Control Units

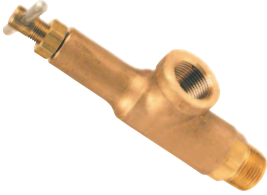

MODEL	MAX. GPM	MAX. PSI	DESCRIPTION	LIST PRICE
6010.95/FH	20	350	Same as 6010.93/FH except regulator is fitted with a lighter spring & gauge for lower pressure applications. <i>Direct replacement for GS40GI on D30 & D50 pumps.</i>	\$246.20
			Repair Kit Part #6062.A9	\$59.60
6005.14/N	64	1000	High volume adjustable brass pressure regulator with master on/off lever, 3/4" male NPT inlet port, 1/4" gauge port & 1-1/4" hose barb bypass port.	\$399.00
			Repair Kit Part #8701.03	\$100.40
6005.15/N	45	1000	High volume adjustable brass pressure regulator with master on/off lever, 3/4" male NPT inlet port, 1/4" gauge port & 1" hose barb bypass port.	\$381.90
			Repair Kit Part #8701.03	\$100.40
UD1/4-150, 300	4.5	150	Anodized aluminum pressure relief valve with 1/4" male NPT inlet & 3/8" female NPT bypass. Available in 150 & 300 PSI models.	\$48.30
	4.5	300		
UD3/4-60/P	30	70	Polypropylene pressure relief valve with 3/4" male NPT inlet & 3/4" female NPT bypass.	\$48.90
				
UD3/4-250/P	30	250	Polypropylene pressure relief valve with 3/4" male NPT inlet & 3/4" female NPT bypass.	\$48.90
				
UD1/2-300	20	300	Brass pressure relief valve with 1/2" male NPT inlet & 1/2" female NPT bypass.	\$61.90
				

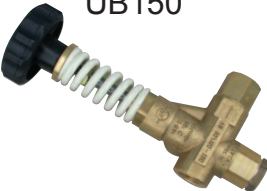
NEW

UDOR Universal Control Units

MODEL	MAX. GPM	MAX. PSI	DESCRIPTION	LIST PRICE
UD3/4-300 	30	300	Brass pressure relief valve with 3/4" male NPT inlet & 3/4" female NPT bypass.	\$69.50
15-2740 	80	300	Cast iron pressure relief valve with 1-1/4" male NPT inlet & 1-1/4" female NPT bypass. Powder coated for corrosion resistance.	\$213.80
1238.N4 	40	400	Brass pressure relief valve with conical machined stainless steel poppet & seat for precision pressure control & minimal pressure rise in bypass. 3/4" male NPT inlet, 3/4" hose barb bypass & 1/4" female NPT gauge port.	\$397.20
			Repair Kit Part #1238.N4/K	\$141.70
UD7100 (yellow) UD7200 (red) UD7300 (blue) UD7400 (black) 	7 8 8 8	1500 3000 3500 4000	Brass bypass unloader valve with 3/8" female NPT inlet, 3/8" female NPT outlet & 3/8" female NPT bypass.	\$89.60
			Repair Kit Part #UD7300/K	\$43.50
UB150 	20	2500	Brass bypass unloader valve with 1/2" female NPT inlet, 1/2" female NPT outlet & 1/2" female NPT bypass.	\$236.50
			Repair Kit Part #UB150/K	\$53.50
UB280 	20	4000	Brass bypass unloader valve with 1/2" female NPT inlet, 1/2" female NPT outlet & 1/2" female NPT bypass.	\$236.50
			Repair Kit Part #UB150/K	\$53.50
UB1500 	52	2200	Brass high volume bypass unloader valve with 1" female NPT inlet, 1" female NPT outlet & 1" female NPT bypass.	\$708.80
			Repair Kit Part #UB1500/K	\$162.50

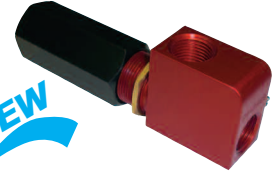
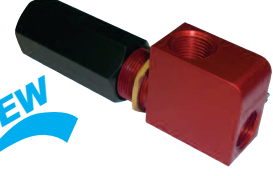
UDOR Universal Control Units

MODEL	MAX. GPM	MAX. PSI	DESCRIPTION	LIST PRICE
 UD500F	7	500	Anodized aluminum pressure relief valve with 3/8" female NPT inlet & 3/8" female NPT bypass.	\$66.00
 UD550F	7	1000	Anodized aluminum pressure relief valve with 3/8" female NPT inlet & 3/8" female NPT bypass.	\$66.00
 UD555FT	7	2000	Brass pressure relief valve with 3/8" female NPT inlet, 3/8" female NPT outlet & 3/8" female NPT bypass.	\$66.00
			Repair Kit Part #UD555/K	\$31.70
 UD600F	35	2500	Brass pressure relief valve with 3/4" female NPT inlet & 1/2" female NPT bypass.	\$275.90

UDOR Spray Boom Control Units

MODEL	MAX. GPM	MAX. PSI	DESCRIPTION	LIST PRICE
SB3	35	300	Remote-mounted control valve provides three, four, five or six section spray boom control & a master on-off lever. Has 3/4" hose barb inlet, 1" hose barb bypass, 1/2" hose barb outlet ports & 1/4" female NPT gauge port. Optional 3/4" hose barb outlet ports are also available (Part #1406.26). Please specify.	\$536.00
SB4	35	300		\$559.10
SB5	35	300		\$580.60
SB6	35	300		\$603.80
			Repair Kit Part #SB3/KIT	\$196.00





UDOR Gauges



MODEL	DESCRIPTION	LIST PRICE
GG350	Glycerine-filled pressure gauge with 1/4" male NPT inlet at the bottom & multi-color dial. Reads in both PSI & Bar. Max. 350 PSI.	\$35.70
GG350/BM	Glycerine-filled pressure gauge with 1/4" male NPT inlet at the back & multi-color dial. Reads in both PSI & Bar. Max. 350 PSI.	\$35.70
GG1000	Glycerine-filled pressure gauge with 1/4" male NPT inlet at the bottom. Reads in both PSI & Bar. Max. 1000 PSI.	\$35.70
GG1000/BM	Glycerine-filled pressure gauge with 1/4" male NPT inlet at the back. Reads in both PSI & Bar. Max. 1000 PSI.	\$35.70
GG1500	Glycerine-filled pressure gauge with 1/4" male NPT inlet at the bottom. Reads in both PSI & Bar. Max. 1500 PSI.	\$35.70

UDOR Accessories

MODEL	MAX. GPM	MAX. PSI	DESCRIPTION	LIST PRICE							
1238.Z6 	20	75	UDOR tank rinsing nozzle is a fluid driven rotational spray head with 360° of tank rising. 1/2" female inlet, 3.70 inches tall. Made of chemical resistant plastic.	\$160.80							
5020.02 	8.0	400	High pressure polypropylene venturi agitator has 3.0 mm stainless steel orifice & 1/2" male inlet port. Venturi action triples the amount of liquid produced by the agitator.	\$21.80							
			PSI		100	200	300	400			
			Inlet GPM		3.5	5.0	6.0	7.0			
			Total GPM		8.5	12.5	15.5	18.5			
163.1.2 	3.5	700	High pressure brass venturi agitator has 1.8 mm ceramic orifice & 1/2" male inlet port. Venturi action triples the amount of liquid produced by the agitator.	\$48.30							
			PSI		100	200	300	400	500	600	700
			Inlet GPM		1.5	2.0	2.5	2.7	3.0	3.3	3.5
			Total GPM		4.0	6.0	7.0	8.0	9.0	10.0	11.5

UDOR Accessories

MODEL	MAX. GPM	MAX. PSI	DESCRIPTION	LIST PRICE	
 0503.50	30	560	UDOR medium pressure self cleaning strainer features heavy duty glass filled nylon construction. Inlet ports are (1) 3/4" female & (1) 1/2" female, outlet ports are (1) 3/4" female & (1) 1/2" female, 50 mesh reinforced stainless steel screen protects spray nozzles from becoming plugged. Overall length is 9" including flush valve.	\$130.00	
			3260.05	Replacement High Pressure 50 Mesh Screen	\$29.50
 144.504.6	40	1000	UDOR high pressure self cleaning strainer features brass construction (2) 3/4" female inlet & (2) 3/4" female outlet ports. 40 mesh stainless screen protects spray nozzles from becoming plugged. Overall length is 9" including flush valve. Body has mounting bracket with two 3/8" holes.	\$178.80	
			219P12	3/4" male NPT Allen plug.	\$9.40
			209P12/8	3/4" male NPT x 1/2" female NPT reducer bushing.	\$6.30
			144.203.11	Replacement High Pressure 40 Mesh Screen	\$56.50
 UD1-16			UDOR large area 1" filters are made of polypropylene & feature a high flow, 16 mesh reinforced stainless steel screen. Specifically designed for use with diaphragm & plunger pumps.	\$48.90	
	3260.03	Replacement 16 Mesh Screen for 1" Filter		\$18.80	
 UD1-1/4-16 UD1-1/2-16			UDOR large area 1-1/4" & 1-1/2" filters are made of polypropylene & feature a high flow, 16 mesh reinforced stainless steel screen. Specifically designed for use with diaphragm & plunger pumps.	\$65.00	
	3260.01	Replacement 16 Mesh Screen for 1-1/4" x 1-1/2" Filters		\$25.80	

UDOR Quick Disconnect Couplers



9200.01









9200.02



9200.09

MODEL	DESCRIPTION	MAX PSI	LIST PRICE
9200.01	3/8" FNPT Coupler Socket	3500	\$6.30
9200.02	3/8" MNPT Coupler Plug	3500	\$2.70
9200.09	3/8" FNPT Coupler Plug	3500	\$2.70

UDOR Accessories

MODEL	DESCRIPTION	LIST PRICE
0637.08 0637.12 	High pressure safety pop off valve to protect system from over pressurization. 0637.08 has 3/8" male NPT inlet & 1/2" hose barb discharge. Max. Flow - 25 GPM. Max. 600 PSI. Relief PSI 720. 0637.12 has 1/2" male NPT inlet & 3/4" hose barb discharge. Max. Flow - 50 GPM. Max. 750 PSI. Relief PSI 850.	\$37.80 \$40.70
9100.02 	3/8" 1-wire braid hose, hose protectors on both ends. 3/8" MNPT swivel end by 3/8" MNPT rigid end. 50 ft length. Max. 4000 PSI.	\$120.90
9100.09 	50 ft hose assembly, spray gun with swivel inlet, 36" insulated spray wand, tip protector & quick couplers. Max. 4000 PSI.	\$227.30
9500.00 	Diaphragm Pump Saver Valve is mounted on a T-fitting between the inlet fitting on the pump & the filter or ball valve on the intake line, to relieve excess intake vacuum due to a closed ball valve or plugged filter, preventing premature failure of the diaphragms. Brass body, stainless steel spring, polypropylene piston & Viton o-ring. Inlet Port 3/4" male NPT VacuumPreset - 8-10" VAC Adjustment Range - 1-12" VAC	\$51.80
34.1302.2 	UDOR root feeder features a nickel plated trigger valve with 1/2" FNPT swivel inlet, trigger guard & molded rubber hand grip, 3/4" stainless steel tubing with adjustable foot bar and stainless steel 4 hole injector nozzle. 42" overall length. Max. 450 PSI. Max. 20 GPM.	\$420.40
1238.C1 	Durable, molded plastic spray shield protects against over spray when spot spraying. Includes 8002 spray tip with quick disconnect & 1/4" female NPT inlet port. Also works well on spray boom & hand gun applications. Measures 14" L x 5" W x 7" H.	\$47.90
0501.28/K 	3/4" 90° hose barb is made of glass-filled nylon for better resistance to abrasive liquids. Can be used with KAPPA Series & RO-70 pumps. Includes mounting bolts & O-Ring. Max. 350 PSI.	\$21.80

UDOR Accessories

MODEL	DESCRIPTION	LIST PRICE
0508.03/K 	3/4" male NPT straight discharge port assembly is anodized aluminum & may be mounted on RO-70 & KAPPA series pumps. Standard on KAPPA-120/150. Includes mounting bolts & O-Ring. Max. 700 PSI.	\$45.20
0508.10 	3/4" male NPT stainless steel control unit adapter mounts into 3/4" female discharge port on ZETA-40/85 pumps to provide a mounting base for 6010.95 & 6010.96 control units.	\$82.90
0508.11 	1-1/4" female NPT bypass adapter for 6005.14 & 6005.15 regulators. Converts bypass hose barb end to 1-1/4" FNPT.	\$90.10
8704.07 	3/4" discharge port features two outlets with interchangeable 3/4" hose barb & plug. Assembly is anodized aluminum & standard on RO-70 pumps. May also be installed on KAPPA series pumps. Includes mounting bolts & O-Ring. Max. 350 PSI.	\$39.30
8704.29 	1/2" female discharge port features 1/2" FNPT outlet, made of anodized aluminum will fit RO-70 & all KAPPA Series pumps. Max. 560 PSI.	\$29.50
1291.B9 	3/4" plated steel straight bypass hose barb, standard on 6047.06/IND control unit, will also fit 6010.24 & 6047.06 control units.	\$56.20
Straight Hose Barbs 	3/8" & 1/2" hose barbs with 1/2" fly nuts in straight configurations. May be used as inlets for UDOR spray guns & as outlets for most UDOR control units.	162.604.23/8" Straight \$10.50 162.604.41/2" Straight \$10.50
	90° Elbow Hose Barbs 	3/8" & 1/2" hose barbs with 1/2" fly nuts in 90° elbow configurations. May be used as inlets for UDOR spray guns & as outlets for most UDOR control units.



UDOR Fittings & Adapters

MODEL	DESCRIPTION	LIST PRICE
207P12/90 	Brass 90° coupler with 3/4" female metric thread by 3/4" female NPT. Installs on 3/4" male metric port of 6010.24, 6010.93, 6010.95 & 6047.06 pump mounted control units to provide a 3/4" female NPT discharge port.	\$26.00
207P12/3 	Galvanized tee with 3/4" female metric thread by 3/4" female NPT. Installs on 3/4" male metric port of 6010.24, 6010.93, 6010.95 & 6047.06 pump mounted control units to provide multiple 3/4" female NPT discharge ports.	\$23.80
207P14/3 	Galvanized tee with 1" female metric thread by 3/4" female NPT. Installs on 1" male metric discharge port of RO-110/130 pumps to provide multiple 3/4" female NPT discharge ports.	\$32.60
207P12/1 	Galvanized tee with 3/4" female NPT ports. Can be used as a discharge fitting on KAPPA-120/GR & KAPPA-150/CC pumps.	\$19.50
207P12/2 	Galvanized street tee with 1 - 3/4" male NPT port, 1 - 3/4" female NPT port & 1 - 3/4" female metric port. Can be used as a discharge fitting on KAPPA-120/CC & KAPPA-150/CC pumps.	\$20.90
207P8 	Brass coupler with 1/2" female metric thread by 1/2" female NPT. Can be used as a discharge port on KAPPA-7/15/18 & IOTA-17/18/20 pumps & as an inlet port for UDOR high performance spray guns.	\$14.80
207P12/8 	Brass coupler with 1/2" female metric thread by 3/4" female NPT. Can be used as a 3/4" female NPT inlet on UDOR high performance spray guns.	\$16.90



UDOR Fittings & Adapters

MODEL	DESCRIPTION	LIST PRICE
207P12/14 	Galvanized coupler with 1" female metric thread by 3/4" female NPT. Installs on 1" male metric outlet port of RO-110/130 pumps to provide 3/4" female NPT discharge port.	\$29.70
207P12 	Brass coupler with 3/4" female metric thread by 3/4" female NPT. Installs on 3/4" male metric port of 6010.24, 6010.93, 6010.95 & 6047.06 pump mounted control units to provide a 3/4" female NPT discharge port. Can also be used as a 3/4" female NPT inlet port for KAPPA-7/15/18 & IOTA-17/18/20 pumps.	\$16.90
207P14 	Brass coupler with 1-1/4" female metric thread by 1-1/4" female NPT. Installs on 1-1/4" male metric inlet port of KAPPA-30/33/40/43/53/55/75 pumps to provide 1-1/4" female NPT inlet.	\$59.50
207P16 	Brass coupler with 1-1/2" female metric thread by 1-1/2" female NPT. Installs on 1-1/2" male metric inlet port of KAPPA-100/120/150, BETA-110/150/200/240 and OMEGA-140/170 pumps to provide a 1-1/2" female NPT inlet.	\$70.90

UDOR Hose Reels, Base Plates & Accessories

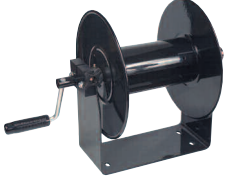

MODEL	DESCRIPTION	LIST PRICE
C5429 	Rubber mounting bushing with molded in washers to support UDOR pumps, base plates & engines. 1-3/4"H x 1-7/8"D.	\$12.00
C8076 	Rubber mounting bushing with molded in washers to support UDOR pumps, base plates & engines. 3/4"H x 1-1/4"D.	\$9.20

UDOR Hose Reels, Base Plates & Accessories

MODEL	DESCRIPTION	LIST PRICE	
9700.00 9700.10	<ul style="list-style-type: none"> • Heavy gauge steel construction • Rough coat powder coat finish • Can be used for gas, electric or hydraulic powered units • Drilled at corners for C5429 vibration dampeners 		
	9700.00 Base Plate. 14" x 26"	\$128.30	
	9700.10 Base Plate. 17" x 30"	\$135.60	
9600.00	<ul style="list-style-type: none"> • 10 GPM, 4000 PSI Max. • Heavy duty steel construction • Adjustable brake • Includes UDOR 3/8" high pressure swivel 	<ul style="list-style-type: none"> • Holds up to 150 feet of 3/8" hose or 75 feet of 1/2" hose • Powder coat finish • Grease fittings on both bearings 	\$316.80
			
9600.10	<ul style="list-style-type: none"> • 15 GPM, 4000 PSI Max. • Heavy duty steel construction • Adjustable brake • Powder coat finish 	<ul style="list-style-type: none"> • Holds up to 300 feet of 3/8" hose or 200 feet of 1/2" hose • Grease fittings on both bearings • Includes UDOR 1/2" high pressure swivel 	\$401.90
			

UDOR Spray Booms & Accessories



MODEL	DESCRIPTION	LIST PRICE
6049.04	20 foot, 3-section spray boom has 1" square tubing & double action folding for easy boom storage. 20 foot boom folds to 7 foot length. UPS SHIPPABLE WITH AN OVERSIZE CHARGE	\$1,026.90
6049.24	16 foot, 3-section spray boom has 1" square tubing & double action folding for easy boom storage. 16 foot boom folds to 6 foot length. UPS SHIPPABLE	\$997.90
6035.02	UDOR spray boom hinge features a universal frame mount & accepts 1" square boom tubing. Break away design features ramp action boom repositioning. Unique design provides double action folding for easy boom storage. Excellent for custom spray boom fabrication.	\$254.20
		
6035.18	UDOR spray boom hinge features a break away design & ramp action boom repositioning. Excellent for custom spray boom fabrication or as a replacement hinge for UDOR spray booms.	\$208.30
		

BASIC PLUMBING DIAGRAM

for Typical Sprayer

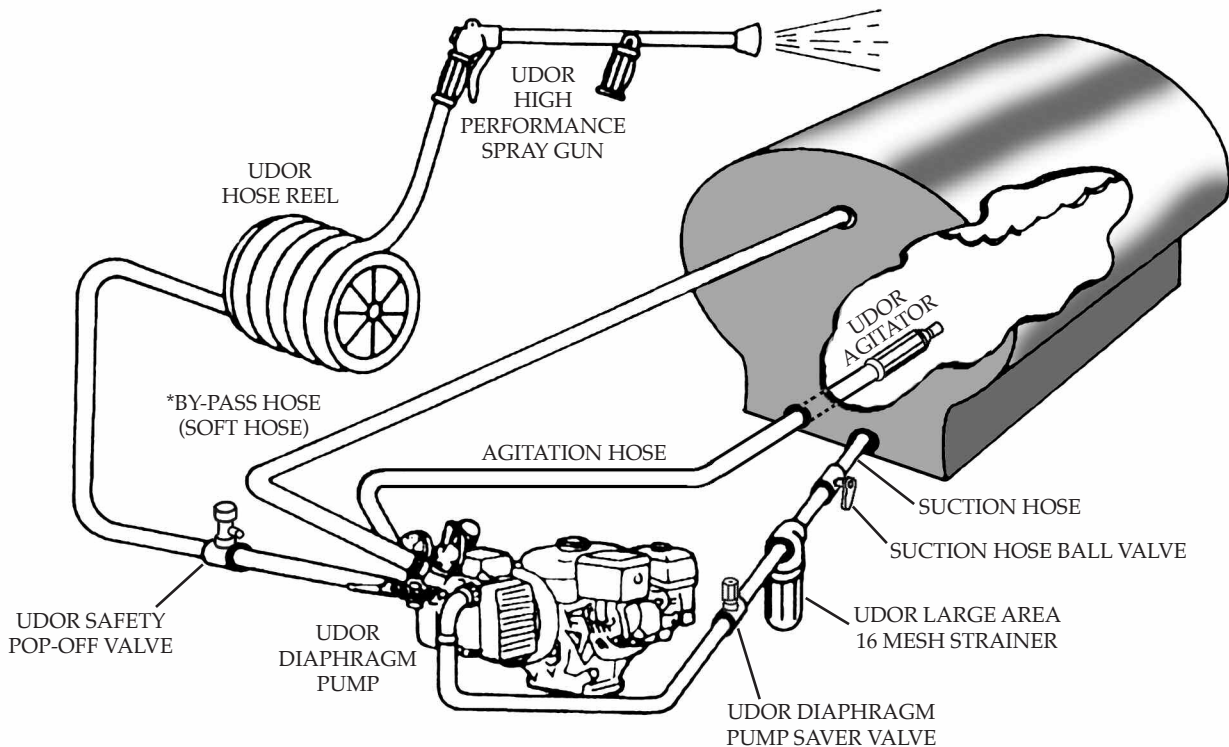

*** IMPORTANT INSTRUCTIONS:**

- **KEEP SUCTION HOSE BALL VALVE OPEN WHENEVER SYSTEM IS BEING OPERATED.**
- **BY-PASS HOSE MUST BE OPEN AND UNRESTRICTED AT ALL TIMES.**
- **NEVER INSTALL AN AGITATOR OR BALL VALVE ON THE BY-PASS HOSE; USE SOFT HOSE ONLY.**
- **NEVER RUN ANY PUMP WITHOUT A PRESSURE CONTROL VALVE OR PRESSURE REGULATOR VALVE INSTALLED.**

NOTE: Protect the pump and system from freezing. If freezing conditions exist, flush the pump, all hoses and complete system with a 50/50 mixture of anti-freeze and water.

ONLY USE FILTER SCREENS THAT ARE BETWEEN 10 & 20 MESH ON THE INLET SIDE OF THE PUMP.

Never use a fine filter screen on the inlet side of a diaphragm pump.

***FAILURE TO FOLLOW THESE IMPORTANT INSTRUCTIONS WILL VOID ANY AND ALL WARRANTY.**



TERMS & CONDITIONS

UDOR USA SALES POLICY

UDOR USA reserves the right to refuse to conduct business with any company that is not in good credit standing or that is not determined to be a qualified equipment manufacturer, wholesaler or distributor.

SHIPPING STOCK ORDERS

All orders shipped by UPS or truck freight only. All UPS freight charges are prepaid and added to the invoice.

ORDER PROCEDURE

To eliminate any ordering errors, we highly recommend faxed orders. Our toll free fax line is open 24 hours a day 1-800-732-2670. Phone order lines are open Monday-Friday 8:00 a.m. - 5:00 p.m. central time 651-785-0666.

MINIMUM ORDER

UDOR USA has a \$25.00 net minimum order requirement.

DROP SHIPS

All drop ships carry a \$15.00 drop ship fee.

OPEN CREDIT TERMS & CONDITIONS

After submitting a signed credit application and receiving credit approval in writing from the UDOR USA credit department, open terms are NET 30 unless otherwise specified by UDOR USA.

FORMS OF PAYMENT

Open credit: after the submission and approval of a UDOR USA credit application; credit cards: VISA & Mastercard are accepted.

PAST DUE INVOICES

Receiving open credit terms from UDOR USA is a result of good faith and your ability to meet payment terms. Invoices are considered past due 31 days after the invoice date, unless otherwise specified by UDOR USA. You will receive a friendly reminder of past due invoices by our credit department.

RETURNED CHECKS

A \$35.00 fee will be charged on all returned checks to UDOR USA by our bank for any reason.

RETURNED ITEMS

Any returned items for account credit only. No credit card or check refunds.



DIAPHRAGM AND GAMMA SERIES PLUNGER PUMPS & ACCESSORIES LIMITED PRODUCT WARRANTY

UDOR Diaphragm and GAMMA Series Plunger Pumps are warranted by the manufacturer to the original purchaser to be free from defects in materials and workmanship under normal use and service for a period of one (1) year.

UDOR Accessories are warranted to be free from defects in materials and workmanship under normal use and service for a period of ninety (90) days.

“Normal use and service” is defined as applications not in excess of recommended maximum speeds, pressures, temperatures or vacuums, only handling fluids which are compatible with pump or accessory materials and maintaining proper oil change intervals.

“Proper oil change intervals” for Plunger Pumps is changing PUMP OIL after the first 50 hour break-in period, and after every 500 hours of use thereafter using UDOR LUBE Premium Pump Oil.

“Proper oil change intervals” for Diaphragm Pumps is changing pump oil and diaphragms at the end of the spraying season or after 500 hours of use, whichever comes first using UDOR LUBE Premium Pump Oil and UDOR USA original equipment parts.

This Warranty DOES NOT APPLY to freight damage, damage due to freezing, running pump dry (plunger pumps only) or improper lubrication of crankcase, normal wear of moving parts, damage due to misuse or misapplication, or damage due to use of parts or accessories not obtained from or approved by UDOR USA.

This Warranty also does not apply to any pump or accessory which has been altered or modified to affect its performance or reliability.

This Warranty excludes all elastomers, such as diaphragms, seals and valves as they are considered “normal wear items.”

All warranty evaluation returns must be accompanied by the original purchase invoice. If invoice is not included, UDOR USA will determine warranty by manufacturer's serial number and date of manufacture on the pump label.

UDOR USA's obligation under this warranty is limited to repair or replacement of product in question, at UDOR's option, upon return of the product, freight prepaid, to UDOR USA. UDOR USA agrees to be responsible for return shipping costs ONLY on any approved warranty repair or replacement product via ground transportation ONLY. This warranty is in lieu of all other warranties expressed or implied, including any warranty of merchantability and any warranty of fitness for a particular purpose.

IN NO EVENT SHALL UDOR USA BE LIABLE FOR ANY INCIDENTAL OR CONSEQUENTIAL DAMAGES OR EXPENSES OF ANY KIND. This includes lost income, travel time and expenses, lodging expenses, labor expenses, down time, shipping costs and any other incidental or consequential damages or expenses.

WARNING! - DO NOT PUMP OR FLUSH PUMP WITH FLAMMABLE OR EXPLOSIVE FLUIDS. DO NOT USE ANY OF THESE PRODUCTS IN AN EXPLOSIVE ATMOSPHERE. FAILURE TO FOLLOW THIS WARNING CAN RESULT IN PERSONAL INJURY OR PROPERTY DAMAGE AND WILL VOID ANY AND ALL WARRANTIES.

This Warranty supersedes any and all previous Warranties.



**Large Enough to Do the Job,
Small Enough to Care.**

UDOR USA
500 Apollo Drive
Lino Lakes, MN 55014
Phone: 651-785-0666
Fax: 800-732-2670
Email: info@udorusa.com
www.udorusa.com

2011 Price List